

2009 / 10

Gear Pump Manufacturing

Getting the World into Gear

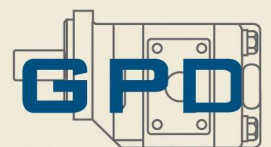
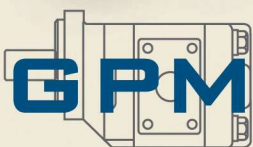
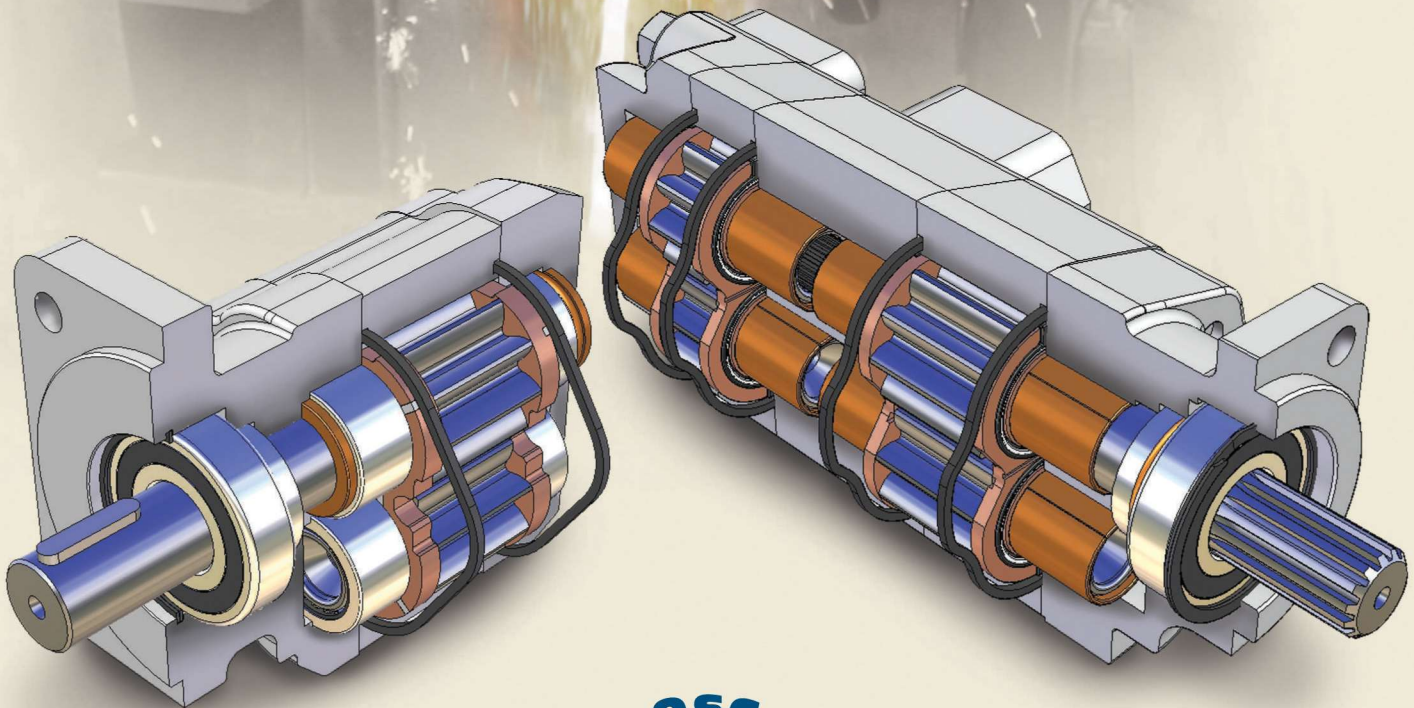

Manufactured in South Africa

BUSHING RANGE

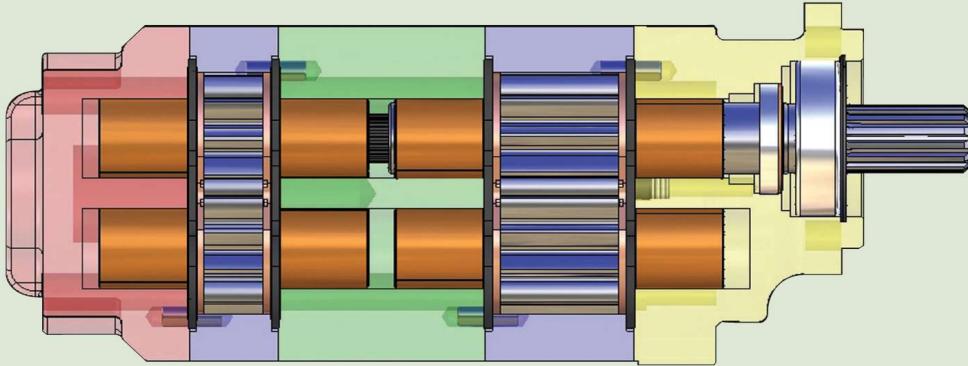

Pump & Motor Specifications

CODE

Manufactured in South Africa

DASH SIZE GEAR WIDTH	-05 0.50"(1/2")	-07 0.75"(3/4")	-10 1.00"(1")	-12 1.25"(1 1/4")	-15 1.50"(1 1/2")	-17 1.75"(1 3/4")	-20 2.00"(2")	-22 2.25"(2 1/4")	-25 2.50"(2 1/2")
215									
Gear Housing Width	0.88"(7/8")	1.13"(11/8")	1.38"(13/8")	1.63"(15/8")	1.88"(17/8")	2.13"(21/8")	2.38"(23/8")		
cc/rev	10.00	15.00	20.00	25.00	30.00	35.00	40.00		
Lpm (at 1000rpm)	10.00	15.00	20.00	25.00	30.00	35.00	40.00		
cu in (cu in/rev)	0.61	0.92	1.22	1.53	1.84	2.15	2.44		
US gpm (at 1000rpm)	4.23	6.37	8.51	10.65	12.76	14.90	17.04		
Max Pressure(bar)	240	240	240	240	220	200	170		
Max Pressure(psi)	3500	3500	3500	3500	3200	2900	2500		
Max Speed (rpm)	3000	3000	3000	3000	3000	3000	3000		
Pump Weight (kg)	8.00	8.00	8.00	8.50	9.00	9.50	10.00		
Additional sect add (kg)	8.00	8.00	8.00	8.50	9.00	9.50	10.00		
230									
Gear Housing Width	1.00"(1")	1.25"(1 1/4")	1.50"(1 1/2")	1.75"(1 3/4")	2.00"(2")	2.25"(2 1/4")	2.50"(2 1/2")		
cc/rev	16.00	24.10	32.20	40.30	48.30	56.40	64.50		
Lpm (at 1000rpm)	16.00	24.10	32.20	40.30	48.30	56.40	64.50		
cu in (cu in/rev)	0.99	1.48	1.97	2.46	2.96	3.45	3.94		
US gpm (at 1000rpm)	4.23	6.37	8.51	10.65	12.76	14.90	17.04		
Max Pressure(bar)	240	240	240	240	240	220	200		
Max Pressure(psi)	3500	3500	3500	3500	3500	3250	3000		
Max Speed (rpm)	3000	3000	3000	3000	3000	3000	3000		
Pump Weight (kg)	16.00	16.00	16.00	16.60	17.20	17.80	18.40		
Additional sect add (kg)	14.40	14.40	14.40	14.90	15.50	16.00	16.60		
250									
Gear Housing Width	1.00"(1")	1.25"(1 1/4")	1.50"(1 1/2")	1.75"(1 3/4")	2.00"(2")	2.25"(2 1/4")	2.50"(2 1/2")	2.75"(2 3/4")	3.00"(3")
cc/rev	20.80	31.20	41.70	52.10	62.60	73.00	83.50	94.00	104.40
Lpm (at 1000rpm)	20.80	31.20	41.70	52.10	62.60	73.00	83.50	94.00	104.40
cu in (cu in/rev)	1.28	1.91	2.55	3.19	3.82	4.46	5.10	5.74	6.38
US gpm (at 1000rpm)	5.50	8.24	11.02	13.76	16.54	19.29	22.06	24.84	27.58
Max Pressure(bar)	240	240	240	240	240	220	200	190	170
Max Pressure(psi)	3500	3500	3500	3500	3500	3250	3000	2750	2500
Max Speed (rpm)	2400	2400	2400	2400	2400	2400	2400	2400	2400
Pump Weight (kg)	22.70	22.70	22.70	23.40	24.10	24.80	25.50	26.20	26.90
Additional sect add (kg)	22.70	22.70	22.70	23.40	24.10	24.80	25.50	26.20	26.90
265									
Gear Housing Width		1.25"(1 1/4")	1.50"(1 1/2")	1.75"(1 3/4")	2.00"(2")	2.25"(2 1/4")	2.50"(2 1/2")	2.75"(2 3/4")	3.00"(3")
cc/rev		44.00	59.00	73.50	88.00	102.00	118.00	132.60	147.00
Lpm (at 1000rpm)		44.00	59.00	73.50	88.00	102.00	118.00	132.60	147.00
cu in (cu in/rev)		2.68	3.60	4.49	5.37	6.22	7.20	8.09	8.97
US gpm (at 1000rpm)		11.62	15.59	19.42	23.25	26.95	31.18	35.03	38.84
Max Pressure(bar)		240	240	240	240	240	240	220	200
Max Pressure(psi)		3500	3500	3500	3500	3500	3500	3250	3000
Max Speed (rpm)		2400	2400	2400	2400	2400	2400	2400	2400
Pump Weight (kg)		24.90	24.90	26.00	27.10	28.20	29.30	30.40	31.50
Additional sect add (kg)		22.70	22.70	23.40	24.10	24.80	25.50	26.20	26.90

THE ABOVE DATA ARE AVERAGE RESULTS BASED ON A SERIES OF TESTS AND ARE NOT NECESSARILY REPRESENTATIVE OF ANY SINGLE UNIT. GEAR PUMP MANUFACTURING RESERVES THE RIGHT TO AMEND THE TECHNICAL DATA WITHOUT NOTICE.

Useful Formulae	To Convert	Inches	Bar	Cu In/rev	US GPM	US GPM	kg
	Into	Millimeters	Psi	cc/rev	Cu In/rev	cc/rev	lbs
	Multiply by	25.4	14.5	16.39	2.31	3.785	2.205

GP = PUMP
GM = MOTOR
GF = FLOW DIVIDER
GA = ADD ON
GB = STEP DOWN
GZ = PUMP / MOTOR COMBO

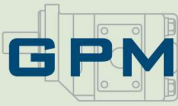

BUSHING RANGE - Quick Reference

	215	230	250	265
A SOLID SHAFT GEAR SET				
7/8" KEY SAE B		ADC-230-??		
7/8" KEY SHORT SAE B	ADK-215-??			
1" KEY SAE BB		AEC-230-??	ATF-250-??	
1 1/4" KEY SAE C			ASF-250-??	AAG-265-??
9 SPLINE 5/8" SHORT SAE A	AZK-215-??			
13 SPLINE 7/8" SAE B		ABC-230-??	AVF-250-??	ABG-265-??
13 SPLINE 7/8" SHORT SAE B	ABK-215-??	ABC-230-4-??		
14 SPLINE 1 1/4" SAE C			APF-250-??	ANG-265-??
15 SPLINE 1" SAE BB		AAC-230-??	AAF-250-??	
**PLEASE CONTACT GPM FOR SPECIALS • SUBSTITUTE ?? WITH CORRECT GEAR SIZE CODE				
B LOOSE GEAR SETS				
STANDARD	BVK-215-??	BVC-230-??	BMF-250-??	BPG-265-??
**ALSO MAKE SERIES 115 = BBA-115-?? • **ALSO MAKE SERIES 137 = BJA-137-?? • SUBSTITUTE ?? WITH CORRECT GEAR SIZE CODE				
C GEAR HOUSINGS				
PUMP	CRK-215-??	CRC-230-??	CMH-250-??	CSG-265-??
MOTOR	CLK-215-??	CSC-230-??	CLF-250-??	CLG-265-??
PUMP - BI ROTATION				
SUBSTITUTE ?? WITH CORRECT GEAR SIZE CODE				
D SHAFT END COVERS				
2 BOLT 3.25" SAE A	DWK-215			
2 BOLT 3.25" SAE A WITH S/RETAINER	DWK-215-SPL			
2 BOLT 3.25" SAE A MOTOR	DWK-215-M			
2 BOLT 4" SAE B	DGK-215	DGC-230	DRF-250	DRG-265
2 BOLT 4" SAE B MOTOR	DGK-215-M			DRG-265-M
2 BOLT 4" SAE B SHORT		DGC-230-SH		
2 BOLT 5" SAE C		DNC-230	DNF-250	DVG-265
2 BOLT 5" SAE C MOTOR				DVG-265-M
4 BOLT 4" SAE B	DEK-215	DEC-230	DHF-250	DSG-265
4 BOLT 4" SAE B MOTOR				DSG-265-M
4 BOLT 5" SAE C		DPC-230	DKF-250	DTG-265
4 BOLT 5" SAE C MOTOR				DTG-265-M
4 BOLT DIN PTO			DZF-250	
2/4 BOLT 4" SAE B			DDB-250-4	
2/4 BOLT 5" SAE C			DDB-250-5	
PAD MOUNT MOTOR	DFK-215-M			
E PORT END COVERS				
PORTED	EUK-215	EUC-230	EWf-250	EWG-265
PORTED 4 PORT	EUK-215-4	EUC-230-4	EWf-250-4	
TANDEM	EXK-215	EXC-230	EZF-250	EYG-265
MOTOR	EUK-215-M	EUC-230-M	EUF-250-M	EWG-265-M
MOTOR TANDEM				EYG-265-M
FAN MOTOR	EPK-215-M			
STEP DOWN CW		EPB-230/215 CW	EPB-250/215 CW	EPB-265/230 CW
STEP DOWN CCW		EPB-230/215 CCW	EPB-250/215 CCW	EPB-265/230 CCW
ADD ON 2 BOLT A CW			EAAP250 2bA CW	EAAP265 2bA CW
ADD ON 2 BOLT A CCW			EAAP250 2bA CCW	EAAP265 2bA CCW
ADD ON 2 BOLT B CW			EAAP250 2bB CW	EAAP265 2bB CW
ADD ON 2 BOLT B CCW			EAAP250 2bB CCW	EAAP265 2bB CCW
F BEARING CARRIERS				
1 OUTLET	FYK-215-1	FWC-230-1	FTF-250-1	FZG-265-1
2 OUTLET	FYK-215-2	FWC-230-2	FTF-250-2	FZG-265-2
MOTOR	FYK-215-M	FWC-230-M	FTF-250-M	FZG-265-M
3" SUCTION				FZG-265-3
G THRUST PLATES				
PUMP	GCI-215	GCI-230	GCI-250	GCI-265
MOTOR	GM-215	GM-230	GM-250	GM-265
H THRUST PLATE SEALS				
PUMP CHANNEL SEAL H1	HCI-215-CS	HCI-230-CS	HCI-250-CS	HCI-265-CS
PUMP CHANNEL SEAL BACKUP H2	HCI-215-CSBU	HCI-230-CSBU	HCI-250-CSBU	HCI-265-CSBU
MOTOR SEAL BACKUP H3	HM-215-MSBU	HM-230-MSBU	HM-250-MSBU	HM-265-MSBU
MOTOR END SEAL H4	HM-215-MES	HM-230-MES	HM-250-MES	HM-265-MES
MOTOR SIDE SEAL H5	HM-215-MSS	HM-230-MSS	HM-250-MSS	HM-265-MSS
I CONNECTING SHAFTS				
STANDARD	IZK-215	IZC-230	IYF-250	IAG-265
STEP DOWN		IPB-230/215	IPB-250/215	IPB-265/230
ADD ON TO 9 SPLINE			IAAP-250/9SPL	IAAP-265/9SPL
ADD ON TO 13 SPLINE			IAAP-250/13SPL	IAAP-265/13SPL
ADD ON TO 15SPLINE				IAAP-265/15SPL



All product listed herein is product manufactured and/or supplied by Gear Pump Manufacturing (Pty) Limited ("GPM"), a South African manufacturer and supplier of replacement parts and components.
 "Commercial Intertech" is a registered trademark or copyright of the Parker Hannifin Corporation ("Parker"). Any reference to this entity, its trademark, copyright, product or reference number, is for product comparison and reference purposes only and as such, any referral thereto should not be construed as implying in any way that Parker product is manufactured or supplied by GPM or that GPM is in any way associated with Parker."

BUSHING RANGE - Quick Reference

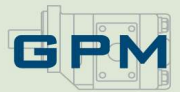

	215	230	250	265
J LOOSE SHAFTS				
7/8" KEY		JCK-230		
1" KEY	JGD-215	JCD-230		
1 1/8" KEY		JHH-230	JHH-250	
1 1/4" KEY		JCW-230		
14 SPLINE 1 1/4"		JCH-230		
15 SPLINE 1"			JFG-250	
17 SPLINE				JKG-265
K BEARINGS/BUSHES				
BUSHES K2	KBUSH-215	KBUSH-230	KBUSH-250	KBUSH-265
SHAFT BALL BEARING K1	KX-131-40	KX-151-58	KX-176-59	
ADD ON		KAAP-250/265	KAAP-250/265	
L SEALS				
BODY SEALS L2	LUB-215-239	LUB-131-242	LUB-250-244	LUB-265-250
MOTOR BODY SEAL	LUB-215-239M			
PUMP SEAL STANDARD L1	LX-215	LX-131-16	LX-151-17	LX-176-10
MOTOR SEAL STANDARD	LX-215-M	LX-131-9	LX-151-8	LX-176-1
PUMP SEAL TELLTALE			LPA-250-TT	
PUMP SEAL LOOSE SHAFT		LX-131-18		
MOTOR SEAL LOOSE SHAFT		LX-131-11		
PUMP SEAL VITON		LX-131V-16	LX-151V-17	LX-176V-10
M RETAINERS				
SEAL RETAINER TELLTALE		MNA-230-1	MPA-250	MTT-265
N DOWELS				
STANDARD	NDOWEL-215	NDOWEL-131	NDOWEL-131	NDOWEL-265
MOTOR				NDOWEL-265M
Q SPACER				
SEAL SPACER	QAE-215	QAE-131	QAC-151	
BEARING SPACER		QVB-131-2	QVB/AC-151	QVB-176
SHAFT SPACER		QTB-131		QAF-176
R KEYS				
SELECT AS PER KEY SHAFT	RX-??	RX-??	RX-??	RX-??
S SNAP RINGS/CIRCLIPS				
SHAFT		SX-131-100	SX-151-125	SX-176-137
SHAFT END COVER	SX-215	SX-131-206	SX-151-283	SX-176-315
ADD ON			SAAP250/265	SAAP250/265
V FASTENERS				
BOLTS	VBOLT 1/2" X ?	VBOLT 5/8" X ?	VBOLT 5/8" X ?	VBOLT 5/8" X ?
NUTS V2	VNUT 1/2"	VNUT 5/8"	VNUT 5/8"	VNUT 5/8"
WASHERS V1	VWASHER 1/2"	VWASHER 5/8"	VWASHER 5/8"	VWASHER 5/8"
STUDS 06"-11"	VSTUD 1/2"X6-11	VSTUD 5/8"X6-11	VSTUD 5/8"X6-11	VSTUD 5/8"X6-11
STUDS 11"-16"	VSTUD 1/2"X11-16	VSTUD 5/8"X11-16	VSTUD 5/8"X11-16	VSTUD 5/8"X11-16
STUDS 16"-21"	VSTUD 1/2"X16-21	VSTUD 5/8"X16-21	VSTUD 5/8"X16-21	VSTUD 5/8"X16-21
STUDS 21"-26"	VSTUD 1/2"X21-26	VSTUD 5/8"X21-26	VSTUD 5/8"X21-26	VSTUD 5/8"X21-
<i>ALL STUDS HAVE EXTENDED THREAD ON ONE SIDE AND CAN BE CUT SHORTER TO REQUIRED SIZE</i>				
W SMALL PARTS				
PLUG DRAIN	WX-131-11	WX-131-11	WX-131-11	WX-131-11
PLUG SHAFT END COVER	WT-131-1391	WT-131-1391	WT-131-1391	WT-131-1391
CHECK VALVES	WM-131-1391	WM-131-1391	WM-131-1391	WM-131-1391

Bushing Pump Tandem Options:

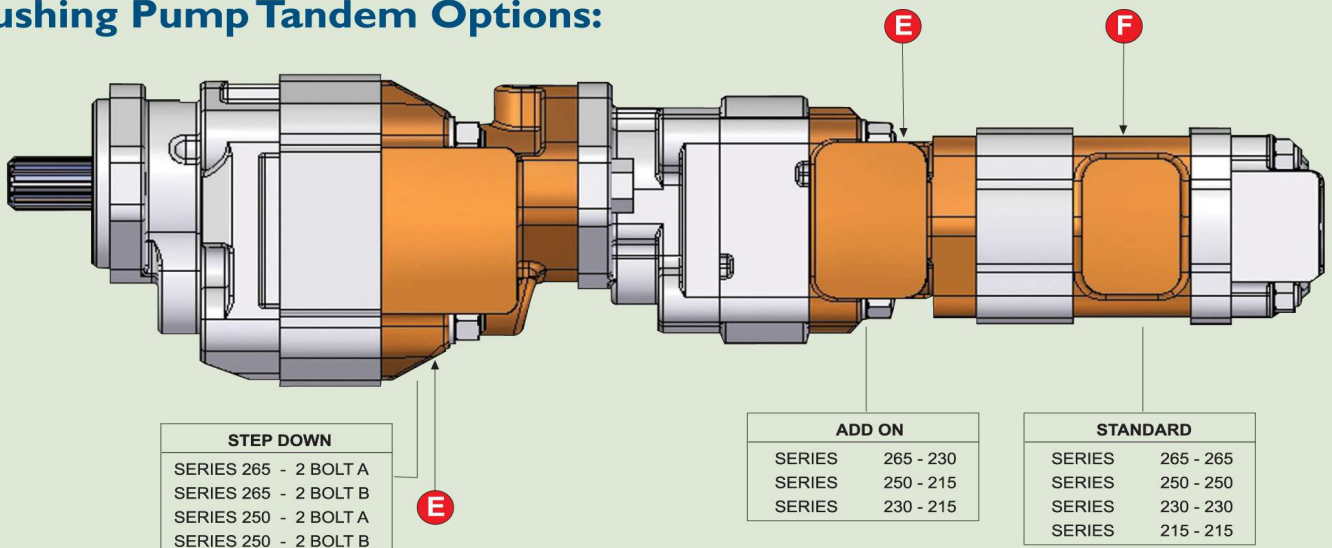

Cape Town - South Africa



Manufacturing Plant (Cape Town)

Gear Pump Manufacturing (Pty) Ltd.
 15 Moody Ave, Epping 1, Cape Town, South Africa
Tel: +27 (0) 21 531 9330
Fax: +27 (0) 21 531 7096
e-mail: sales@gearpumps.co.za
 SALES: markf@gearpumps.co.za
 TECHNICAL: tonyp@gearpumps.co.za
Website: www.gearpumps.co.za

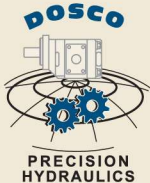

Remanufacturing Facility (Johannesburg)

Dosco Precision Hydraulics (Pty) Ltd.
 No.6 Impangela Road, Sebenza Ext. 6,
 Gauteng, South Africa
Tel: +27 (0) 11 452 5843
Fax: +27 (0) 11 609 7955
e-mail: dosco@dosco.co.za
 SALES: sales@dosco.co.za
 TECHNICAL: gerald@dosco.co.za
Website: www.dosco.co.za



Distributor (Sydney)

Gear Pump Distributors Australia Pty Limited.
 Unit 1, 8 Prince William Drive, Seven Hills, 2147, N.S.W. Australia.
Tel: +61 (0) 2 9674 2298 / 2067
Fax: +61 (0) 2 9674 1934
e-mail: mikee@gearpump.com.au
Website: www.gearpump.com.au



Distributor (Birmingham)

Gear Pump Distributors (UK) Ltd
 Unit 14, Aston Fields Trading Estate, 18 Sugarbrook Road, Bromsgrove,
 Worcestershire B60 3DW
Tel: +44 (0) 1527 880 396
Fax: +44 (0) 1527 880 397
e-mail: stevek@gearpumps.co.uk / lenj@gearpumps.co.uk
Website: www.gearpumps.co.uk



Manufactured in South Africa



Member of the Fluid Power Institute