

# Variable Axial Piston Pump A10V(S)O

**RE 92 701/10.07** 1/44  
Replaces: 11.03

open circuit

Size 18...140  
Series 31  
Nominal pressure 280 bar  
Peak pressure 350 bar

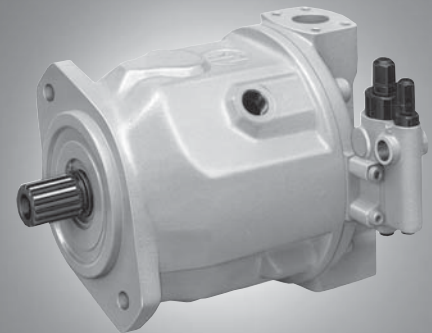

## Contents

Ordering code - standard range	2
Technical data	4
Noise levels	7
Drive power and flows	8
Two position control DG	10
Pressure control DR	12
Pressure control, remote DRG	14
Pressure-flow control DFR	16
Pressure-flow-torque control DFLR	18
Displacement control FHD	20
Unit dimensions size 18	22
unit dimensions size 28	24
Unit dimensions size 45	26
Unit dimensions size 71	28
Unit dimensions size 100	30
Unit dimensions size 140	32
Through drives	34
Overview of through drive mounting options	35
Unit dimensions combination pumps A10V(S)O+A10V(S)O	35
Dimensions through drives	36
Installation notes	40
Safety notes	41

## Features

2	– Axial piston pump A10VO, variable, in swashplate design for hydrostatic transmissions in open loop circuit
4	
7	– Flow is proportional to drive speed and displacement. By adjusting the swashplate angle it is possible to infinitely vary the flow
8	
10	
12	– Mounting flange acc. to SAE J744
14	– Flanged ports acc. to SAE J518
16	– 2 case drain ports
18	– Good suction characteristics
20	– Permissible working pressure 280 bar
22	
24	– Low noise level
26	– Long service life
28	– Axial and radial loading of drive shaft possible
30	– High power to weight ratio
32	– Wide range of controls
34	– Short response times
35	– Through drive option for multiple pump system

# Ordering code standard range

Version		18, 28	45...140						
High-Speed-Version		-	●	H					
Axial piston unit		18	28...140						
Swashplate design variable		-	●	A10V					
		●	-	A10VS					
Mode of operation									0
Size									
Displacement $V_{g \max}$ (cm <sup>3</sup> )		18	28	45	71	100	140		
Control devices		18	28	45	71	100	140		
Two point, direct control	DG	○	●	●	●	●	●	DG	
Pressure control	DR	●	●	●	●	●	●	DR	
	DR	G	●	●	●	●	●	DRG	
remote control									
Pressure and flow control	DFR	●	●	●	●	●	●	DFR	
	DFR	1	●	●	●	●	●	DFR1	
Orifice in X-channel closed									
Pressure, flow and torque control		-	●	●	●	●	●	DFLR	
Pilot pressure dependent displacement control with pressure control		-	●	●	●	●	●	FHD	
Electro-hydr. pressure control, see RE 92707		●	●	●	●	●	●	ED	
Pressure and flow control with electrically adjustable differential pressure see RE (in preparation)		○	●	●	●	●	○	EF	
Series									31
Direction of rotation									
viewed on drive shaft		clockwise							R
		anti-clockwise							L
Seals									
NBR (Nitrile rubber, shaft seal FKM)									P
FKM (Fluoro rubber)									V
Shaft end acc. to SAE J744		18	28	45	71	100	140		
Shaft end (not for through drive) [in]		5/8	-	7/8	-	1 1/4	-	U	
Shaft end (with undercut) [in]		3/4	7/8	1	1 1/4	1 1/2	1 3/4	S	
Shaft end (with runout, higher input torque) [in]		-	7/8	1	1 1/4	-	-	R	
Shaft end [in]		-	-	7/8	-	1 1/4	-	W	

● = available    ○ = in preparation    - = not available

= preferred program

<b>Version</b>	A10V(S) O			/ 31	-				
<b>Axial piston unit</b>									
<b>Mode of operation</b>									
<b>Size</b>									
<b>Control devices</b>									
<b>Series</b>									
<b>Direction of rotation</b>									
<b>Seals</b>									
<b>Shaft end</b>									

**Mounting flange acc. to SAE J744**

	18	28	45	71	100	140	
2-hole	●	●	●	●	●	-	C
4-hole	-	-	-	-	-	●	D

**Port for service lines**

	18	28	45	71	100	140	
Pressure port B } SAE flange rear, suction port S } metric fixing thread	-	●	●	●	●	●	11
Pressure port B } SAE flange on opposite side Suction port S } metric fixing threads	●	●	●	●	●	●	12
Pressure port B } SAE flange rear, suction port S } fixing thread UNC	-	●	●	●	●	●	61
Pressure port B } SAE flange on opposite side suction port S } fixing thread UNC	●	●	●	●	●	●	62

Port plate 11 and 61 only without through drive

**Through drive**

	18	28	45	71	100	140	
Without through drive	●	●	●	●	●	●	N00
With through drive (port plate 12)							
Mounting flange <sup>1)</sup> Shaft/coupling <sup>2)</sup> Sealing							
82-2 (A)            16-4 (A)            axial	●	●	●	●	●	●	K01
82-2 (A)            19-4 (A-B)        axial	●	●	●	●	●	●	K52
101-2 (B)           22-4 (B)           radial	-	●	●	●	●	●	K02
101-2 (B)           22-4 (B)           axial	-	●	●	●	●	●	K68
101-2 (B)           25-4 (B-B)        axial	-	-	●	●	●	○	K04
127-2 (C)           32-4 (C)           axial	-	-	-	●	●	●	K07
127-2 (C)           38-4 (C-C)        axial	-	-	-	-	●	●	K24
152-4 (D)           44-4 (D)           axial	-	-	-	-	-	●	K17

<sup>1)</sup> Flange acc. to ISO 3019-1

<sup>2)</sup> Coupling for splined shaft acc. to SAE J744 OCT83

For mounting options on through drive see page 35.

# Technical data

## Fluid

Prior to project design, please see our data sheets RE 90220 (mineral oil) and RE 90221 (ecologically acceptable fluids) for detailed information on fluids and application conditions. When using ecologically acceptable fluids attention must be paid to possible limitations of the technical data. If necessary please contact us.

### Operating viscosity range

For optimum efficiency and service life we recommend that the operating viscosity (at operating temperature) be selected in the range

$$v_{\text{opt}} = \text{opt. operating viscosity } 16 \dots 36 \text{ mm}^2/\text{s}$$

referred to tank temperature (open loop circuit).

### Limits of viscosity range

The following limits are valid for extreme operating conditions:

$$v_{\text{min}} = 10 \text{ mm}^2/\text{s}$$

short term ( $t \leq 1 \text{ min}$ )  
at a max. permissible oil temperature of 115 °C.

Please note, that the max. fluid temperature of 115 °C is also not exceeded in certain areas (for instance bearing area). The temperature in the bearing area is approx. 5 K higher than average leakage fluid temperature.

$$v_{\text{max}} = 1600 \text{ mm}^2/\text{s}$$

short term ( $t \leq 1 \text{ min}$ )  
on cold start  
( $t_{\text{min}} = p \leq 30 \text{ bar}, n \leq 1000 \text{ min}^{-1}, -40 \text{ °C}$ ).

At temperatures between -25 °C and -40 °C special measures may be required for certain installation positions. Please contact us for further information.

For detailed information on operation at very low temperatures see RE 90300-03-B.

When operating at temperatures between +90 °C and 115 °C use FKM-seals (code designation V).

### Notes on the selection of hydraulic fluid

In order to select the correct fluid, it is necessary to know the operating temperature in the tank (open circuit) in relation to the ambient temperature.

The hydraulic fluid should be selected so that within the operating temperature range, the viscosity lies within the optimum range ( $v_{\text{opt}}$ ); see shaded section of the selection diagram. We recommend that the higher viscosity grade is selected in each case.

Example: at an ambient temperature of X °C the operating temperature in the tank is 60 °C. In the optimum viscosity range  $v_{\text{opt}}$  (shaded area), this corresponds to viscosity grades VG 46 or VG 68, VG 68 should be selected.

**Important:** The leakage oil temperature is influenced by pressure and speed and is typically higher than the tank temperature. However max. temperature at any point in the system may not exceed 115 °C.

At high temperatures please use FKM seals.

If the above mentioned conditions cannot be kept due to extreme operating parameters or high ambient temperatures, please consult us.

### Filtration of fluid

The finer the filtration, the better the achieved cleanliness of the fluid and the longer the life of the axial piston unit.

To ensure a reliable functioning of the axial piston unit, a minimum cleanliness of

20/18/15 acc. to ISO 4406 is necessary.

At very high fluid temperatures (90 °C up to max. 115 °C) the minimum cleanliness has to be at least

19/17/14 acc. to ISO 4406.

If the above cleanliness classes cannot be met please consult us.

## Selection diagram

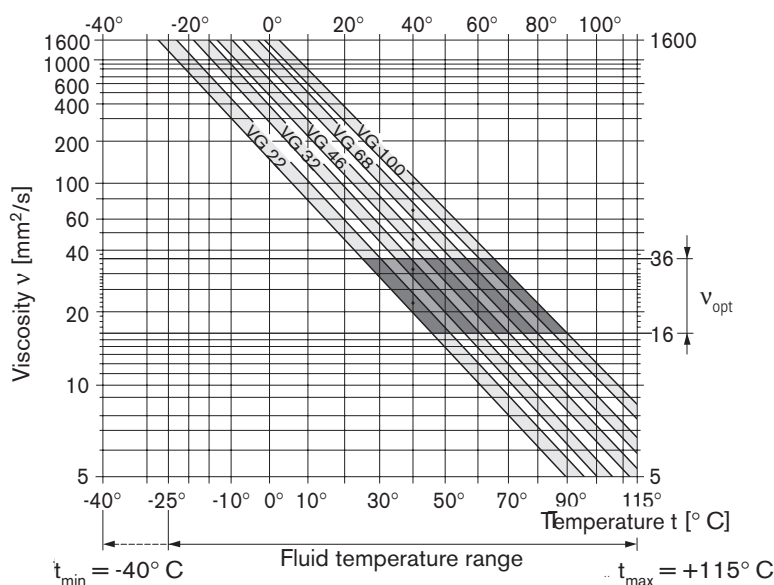

# Technical data (valid for mineral oil; for ecologically acceptable fluids see RE 90221)

## Operating pressure range

### Inlet

Absolute pressure at port S (A)

$P_{abs \min}$  \_\_\_\_\_ 0,8 bar

$P_{abs \max}$  \_\_\_\_\_ 30 bar

### Outlet

Pressure at port B

Nominal pressure  $p_N$  \_\_\_\_\_ 280 bar

Peak pressure  $p_{\max}$  \_\_\_\_\_ 350 bar  
(Pressure data to DIN 24312)

### Case drain pressures

Maximum pressure of leakage fluid (at ports L, L<sub>1</sub>):

maximum 0,5 bar higher than inlet pressure at port S.

$P_{L \max \text{ abs}}$  \_\_\_\_\_ 2 bar

### Direction of flow

**S to B.**

### High speed version

The sizes 45, 71, 100 and 140 are available in a High-Speed-version a.

Without any changes in dimensions, these optimized units are suitable for higher input speeds-see table on page 6.

**Determination of inlet pressure  $p_{abs}$  at inlet port S, or reduction in displacement for increasing speed.**

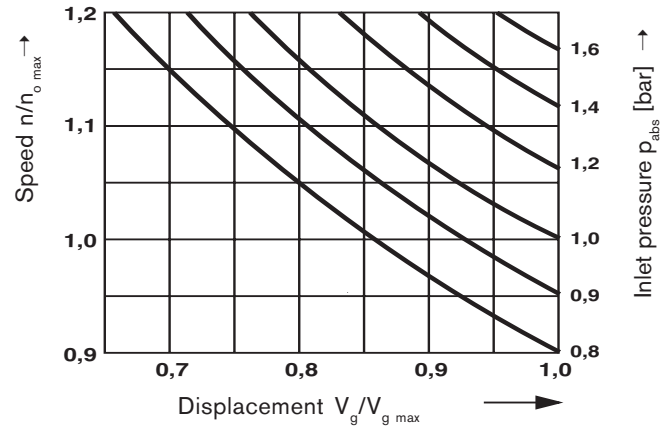

**Table of values** (theoretical values, without considering  $\eta_{mh}$  and  $\eta_v$ : values rounded)

Size	High-Speed-Version												
	18	28	45	71	100	140	45	71	100	140			
Displacement	$V_{g \max}$	cm <sup>3</sup>	18	28	45	71	100	140	45	71	100	140	
Speed <sup>1)</sup>													
max. at $V_{g \max}$	$n_{o \max}$	min <sup>-1</sup>	3300	3000	2600	2200	2000	1800	3000	2550	2300	2050	
max. at $V_g < V_{g \max}$	$n_{o \max \text{ perm.}}$	min <sup>-1</sup>	3900	3600	3100	2600	2400	2100	3300	2800	2500	2200	
Flow													
at $n_{o \max}$	$q_{vo \max}$	L/min	59,4	84	117	156	200	252	135	178	230	287	
at $n_E = 1500 \text{ min}^{-1}$	$q_{vE \max}$	L/min	27	42	68	107	150	210					
at $n_{o \max \text{ perm.}}$	$q_{vo \max \text{ perm.}}$	L/min							149	199	250	308	
Power ( $\Delta p = 280 \text{ bar}$ )													
at $n_{o \max}$	$P_{o \max}$	kW	27,7	39	55	73	93	118	63	83	107	134	
at $n_E = 1500 \text{ min}^{-1}$	$P_{E \max}$	kW	12,6	20	32	50	70	98	32	50	70	98	
Torque													
at $V_{g \max}$	$\Delta p = 280 \text{ bar}$	$T_{\max}$	Nm	80,1	125	200	316	445	623	200	316	445	623
	$\Delta p = 100 \text{ bar}$	$T$	Nm	28,6	45	72	113	159	223	72	113	159	223
Moment of inertia about drive axis	$J$	kgm <sup>2</sup>	0,00093	0,0017	0,0033	0,0083	0,0167	0,0242	0,0033	0,0083	0,0167	0,0242	
Filling capacity		L	0,4	0,7	1,0	1,6	2,2	3,0	1,0	1,6	2,2	3,0	
Weight (without fluid)	$m$	kg	12	15	21	33	45	60	21	33	45	60	
Perm. loading of drive shaft:													
Axial force, max.	$F_{ax \max}$	N	700	1000	1500	2400	4000	4800	1500	2400	4000	4800	
Radial force, max. <sup>2)</sup>	$F_{q \max}$	N	350	1200	1500	1900	2300	2800	1500	1900	2300	2800	

<sup>1)</sup> Values shown are valid for an absolute pressure of 1 bar at inlet port S. At reduced displacement or increased inlet pressure the speed may be increased according to the diagram.

<sup>2)</sup> For higher radial loads, please consult us.

### Determination of size

Flow	$q_v = \frac{V_g \cdot n \cdot \eta_v}{1000}$	[L/min]
Drive torque	$T = \frac{V_g \cdot \Delta p}{20 \cdot \pi \cdot \eta_{mh}}$	[Nm]
Leistung	$P = \frac{2 \pi \cdot T \cdot n}{60 \cdot 1000} = \frac{q_v \cdot \Delta p}{600 \cdot \eta_t}$	[kW]

### Forces

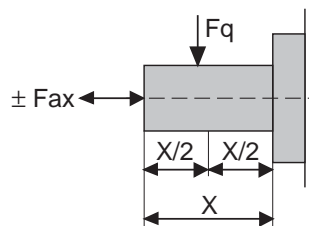

$V_g$  = geometric displacement in cm<sup>3</sup> per rev.

$\Delta p$  = Differential pressure in bar

$n$  = Speed in rpm

$\eta_v$  = volumetric efficiency

$\eta_{mh}$  = mechanical-hydraulic efficiency

$\eta_t$  = Total efficiency ( $\eta_t = \eta_v \cdot \eta_{mh}$ )

# Characteristics for pump with pressure control DR

## Noise characteristic

Measured in an anechoic chamber

Distance microphone-pump = 1 m

Max. measurement error  $\pm 2$  dB (A)

(Fluid: hydraulic oil ISO VG 46 DIN 51519,  $t = 50^\circ$  C)

**Size 18**

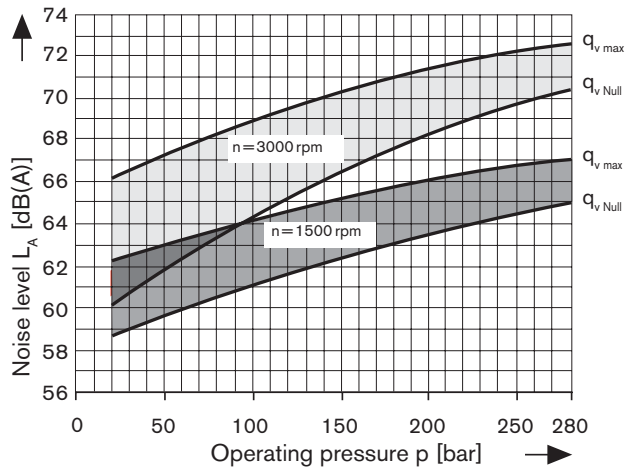

**Size 28**

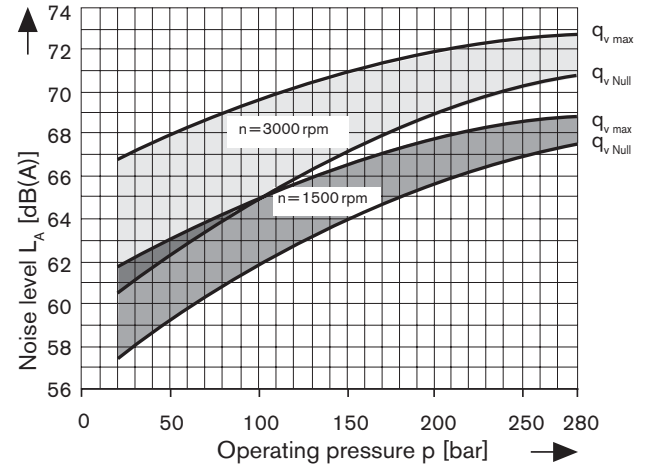

**Size 45**

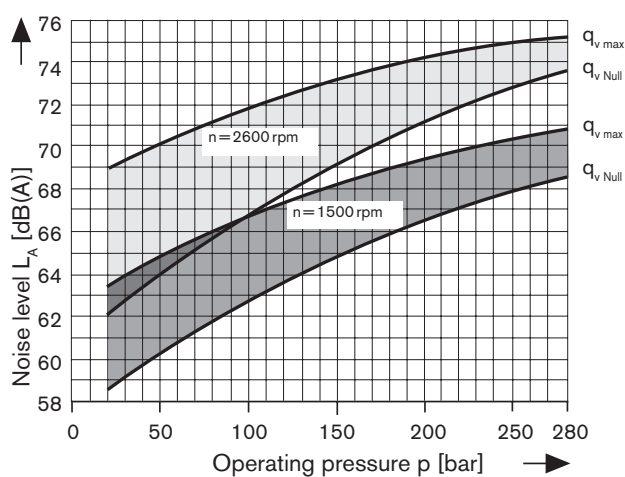

**Size 71**

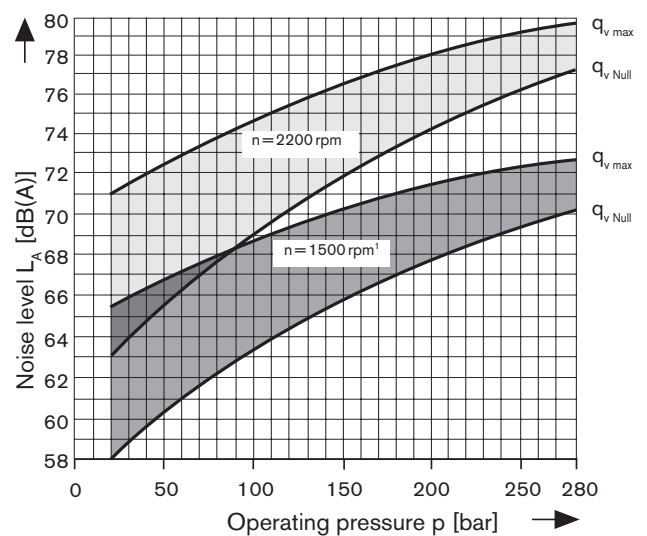

**Size 100**

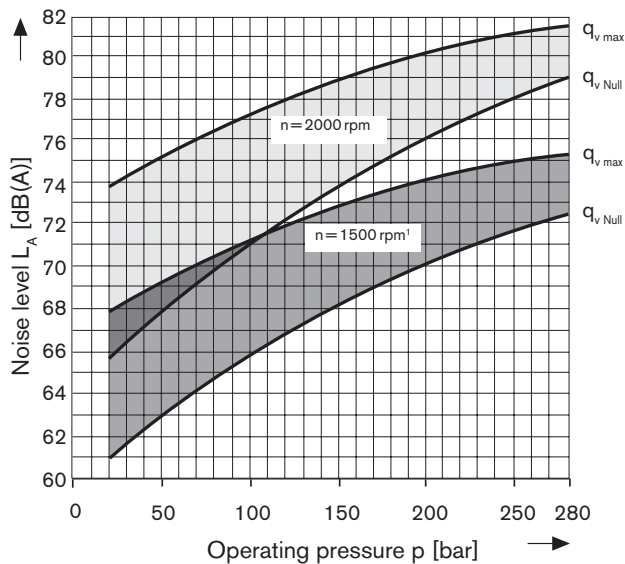

**Nenngröße 140**

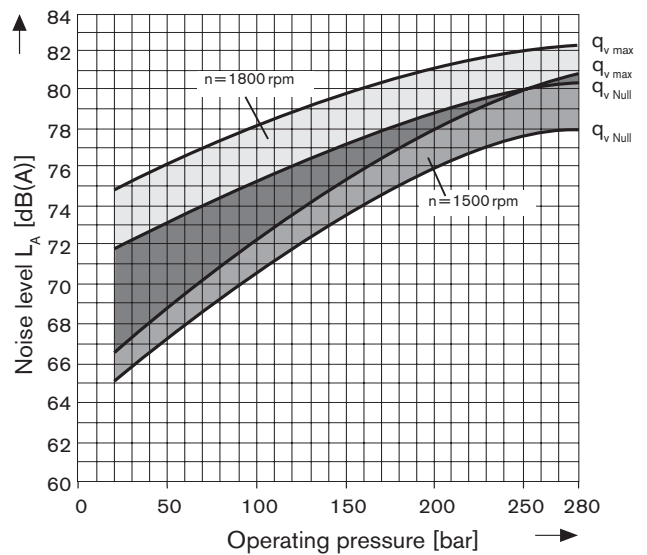

# Drive power and flow

(fluid: hydraulic oil ISO VG 46 DIN 51519,  $t = 50^\circ\text{C}$ )

## Size 18

- n = 1500 rpm
- n = 3300 rpm

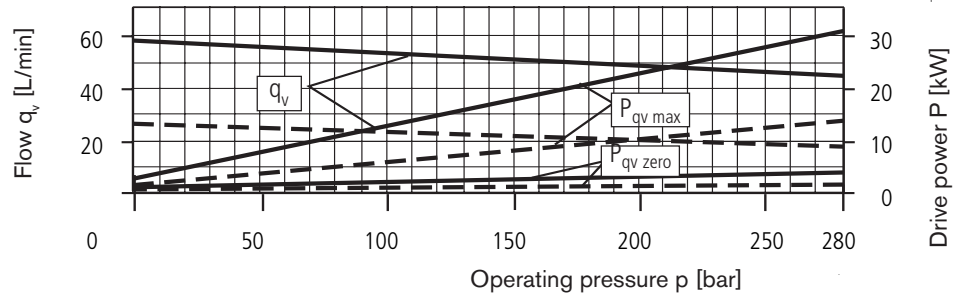

## Size 28

- n = 1500 rpm
- n = 3000 rpm

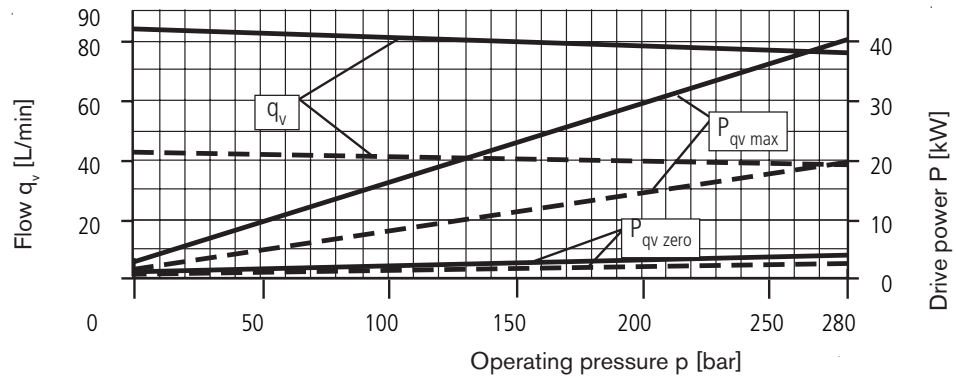

## Size 45

- n = 1500 rpm
- n = 2600 rpm

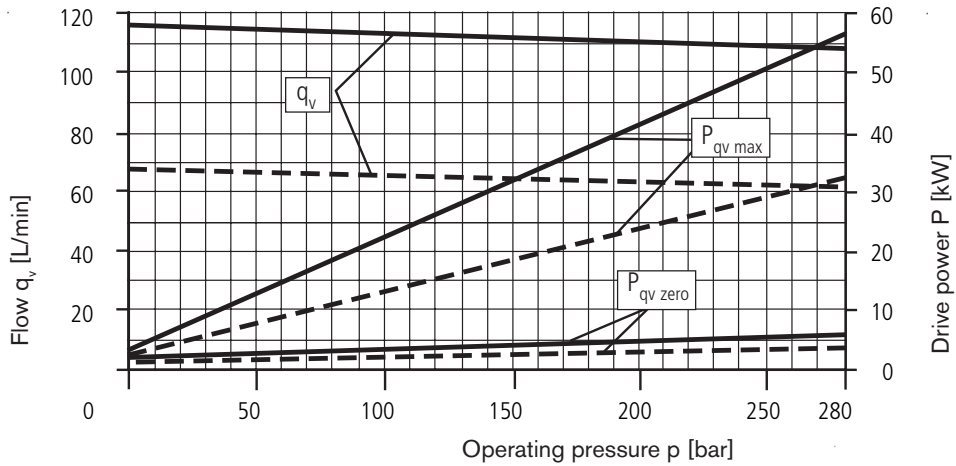

## Size 71

- n = 1500 rpm
- n = 2200 rpm

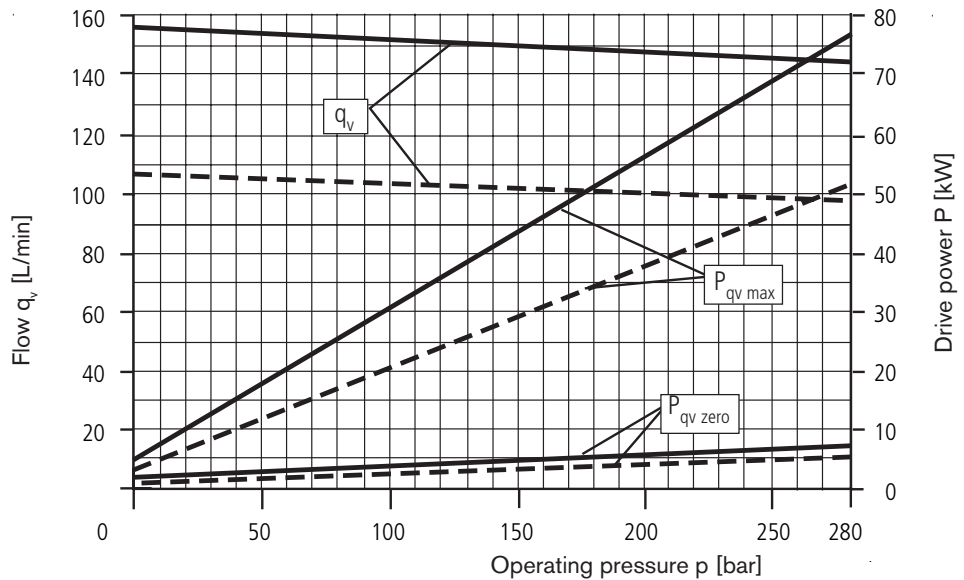



# Drive power and flow

(Fluid: hydraulic oil ISO VG 46 DIN 51519, t = 50° C)

## Size 100

- n = 1500 rpm
- n = 2000 rpm

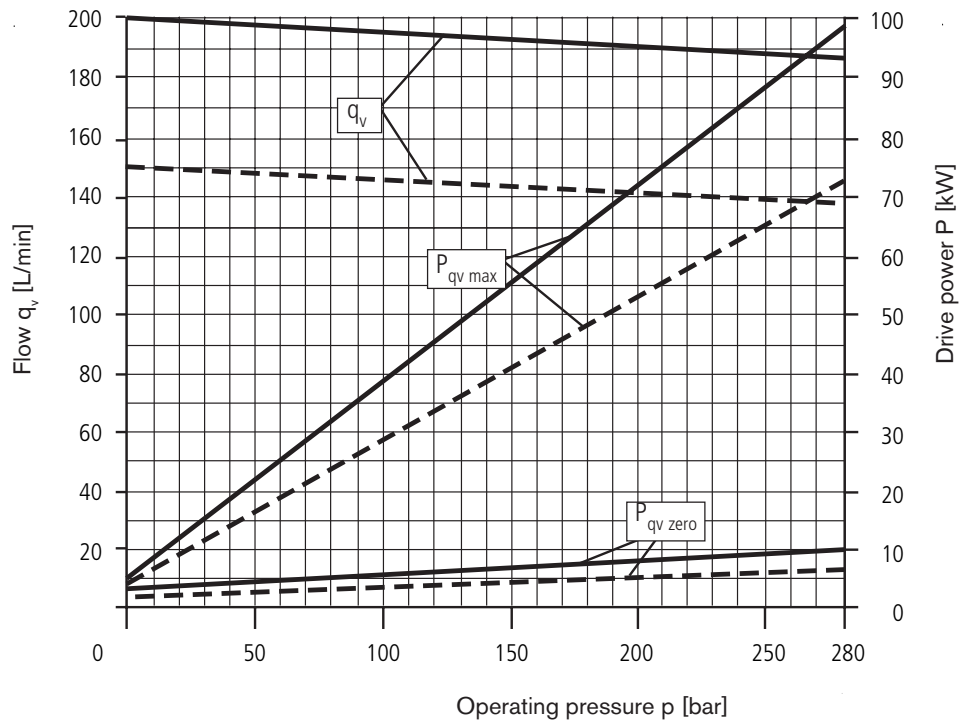

## Size 140

- n = 1500 rpm
- n = 1800 rpm

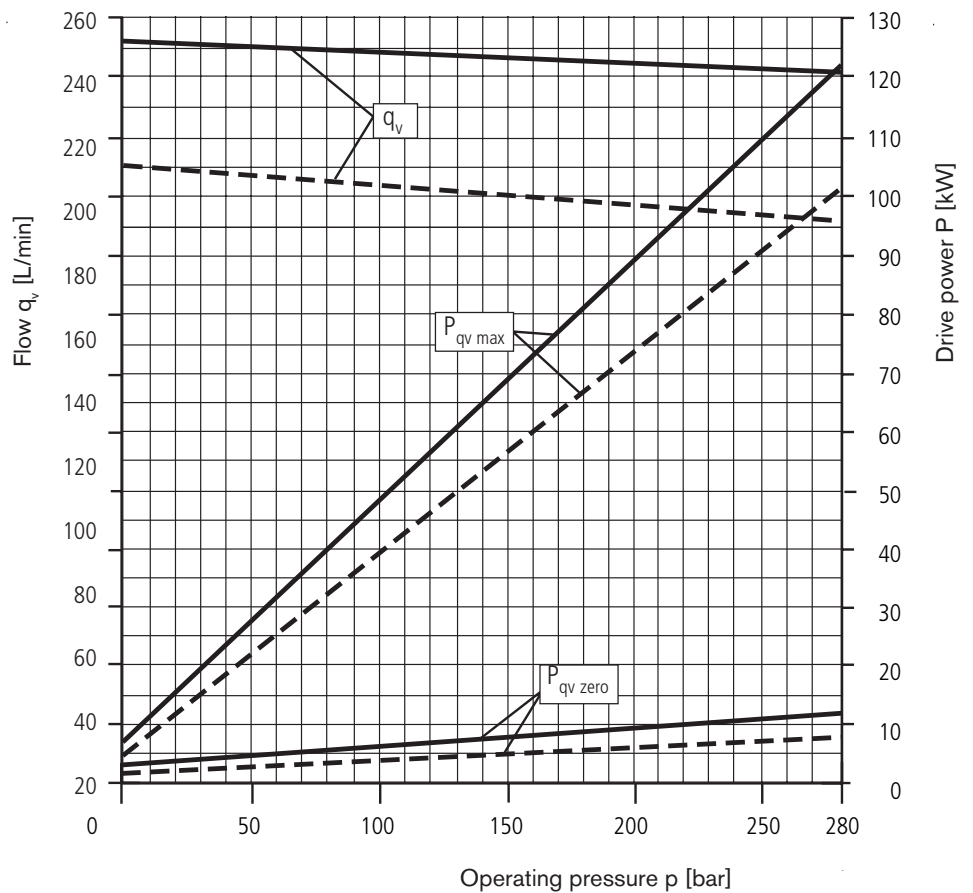

Total efficiency

$$\eta_t = \frac{q_v \cdot p}{P_{qv \max} \cdot 600}$$

Volumetric efficiency:

$$\eta_v = \frac{q_v}{q_{v \text{ theor.}}}$$

## DG - two point, direct control

The pump can be set to a minimum swivel angle by connecting an external switching pressure to port X.

This will supply the control piston directly with control oil; a minimum pressure of 50 bar is required.

The pump can only be switched between  $V_{g \max}$  or  $V_{g \min}$ .

Please note, that the required switching pressure at port X is directly dependent on the actual operating pressure  $p_B$  in port B. (See switching pressure diagram)

Control pressure  $p_{St}$  in X = 0 bar  $\hat{=}$   $V_{g \max}$

Control pressure  $p_{St}$  in X  $\geq$  50 bar  $\hat{=}$   $V_{g \min}$

The max. permissible switching pressure  $p_{St}$  is 280 bar.

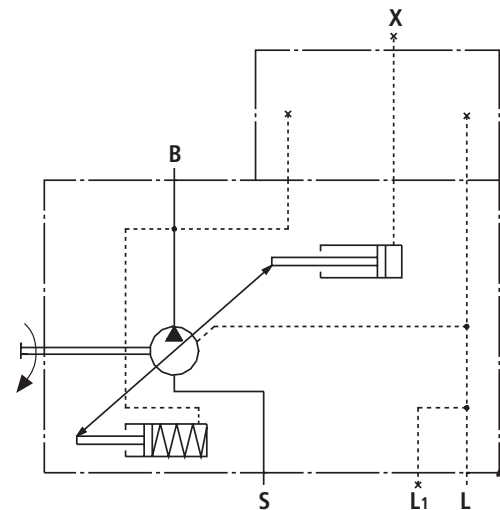

### Switching pressure diagram

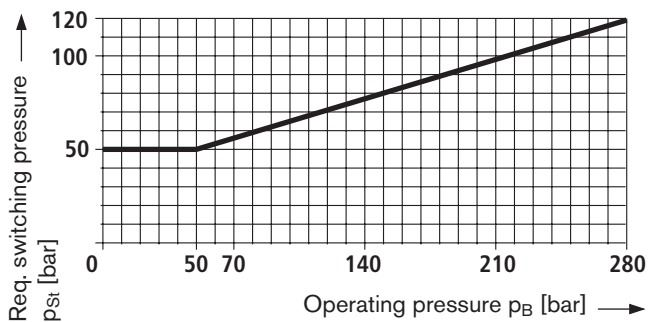

### Ports

- B Pressure port
- S Inlet port
- L, L1 Drain ports (L1 closed)
- X Control port (closed)

# Unit dimensions DG

Before finalising your design please request a certified installation drawing. Subject to revision.

## Version 11 N00 and 61 N00 - Ports at rear

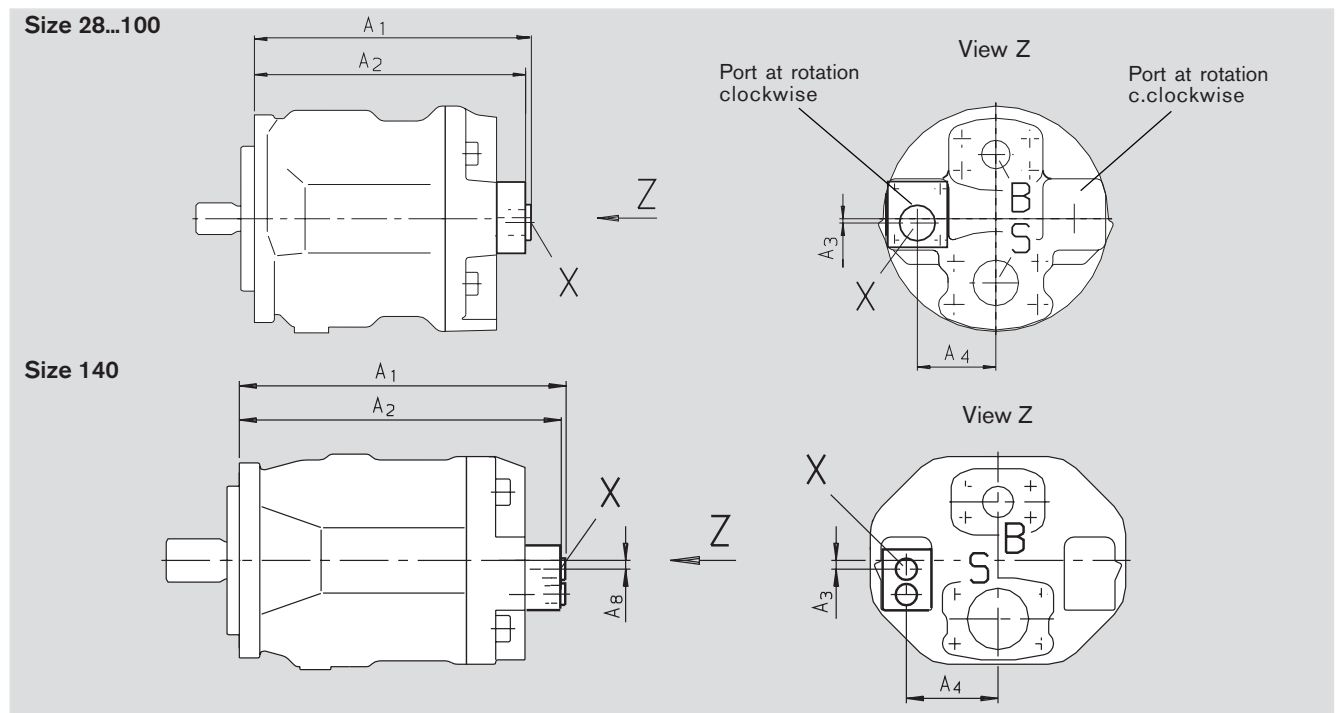

## Version 12 N00 and 61 N00 - Ports on side

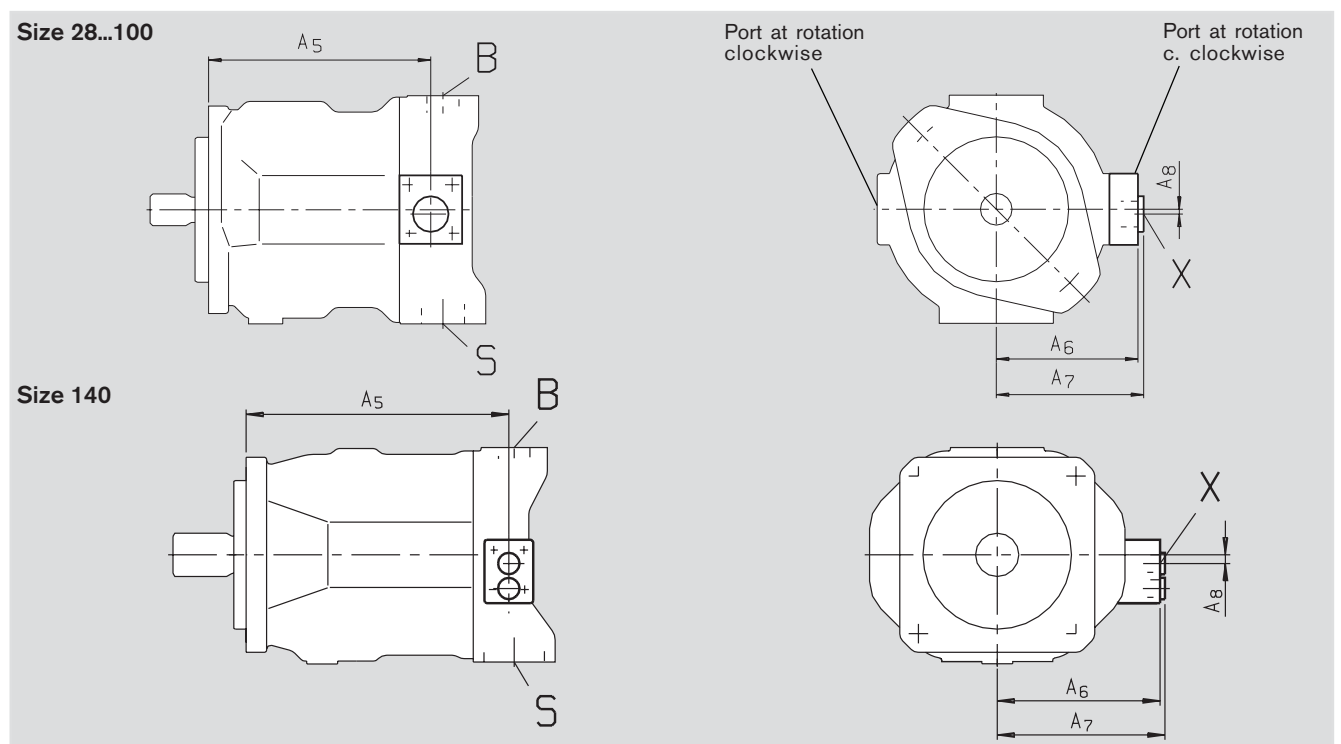

Size	A <sub>1</sub>	A <sub>2</sub>	A <sub>3</sub>	A <sub>4</sub>	A <sub>5</sub>	A	A <sub>7</sub>	A <sub>8</sub>	X (closed )
28	193,5	190	0	55	158	100	103,5	3	R 1/4 in - DIN 3852-1
45	212,5	209	3	63,5	173	110	113,5	3	R 1/4 in - DIN 3852-1
71	246,5	242,5	3	73,5	201	123,5	127,5	3	R 1/4 in - DIN 3852-1
100	311,5	307,5	3	81	268	128,5	132,5	3	R 1/4 in - DIN 3852-1
140	338	334	3	94	268	150,5	155	3	M14x1,5 - DIN 3852-1

# DR - Pressure control

The pressure control serves to maintain a constant pressure in the hydraulic system, within the control range of the pump. The pump therefore supplies only the amount of hydraulic fluid required by the actuators. Pressure can be steplessly set at the pilot valve.

### Static characteristic

(at  $n_1 = 1500 \text{ rpm}$ ;  $t_{oil} = 50^\circ \text{ C}$ )

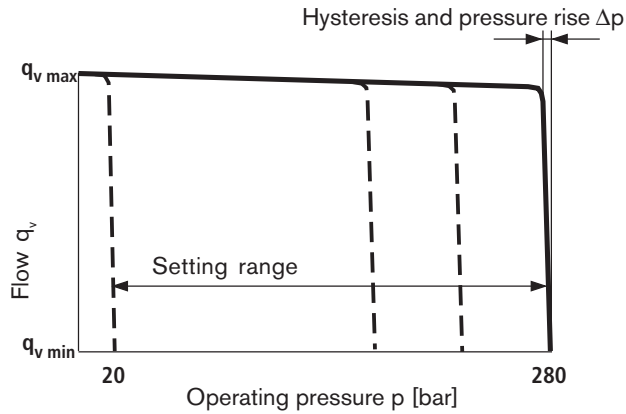

### Dynamic characteristics

The curves show average measured values under test conditions.

Conditions:  $n = 1500 \text{ rpm}$

$t_{oil} = 50^\circ \text{ C}$

Line main relief set at 350 bar

Stepped loading by suddenly opening or closing the pressure line using a pressure relief valve at 1 m downstream from the pump pressure outlet.

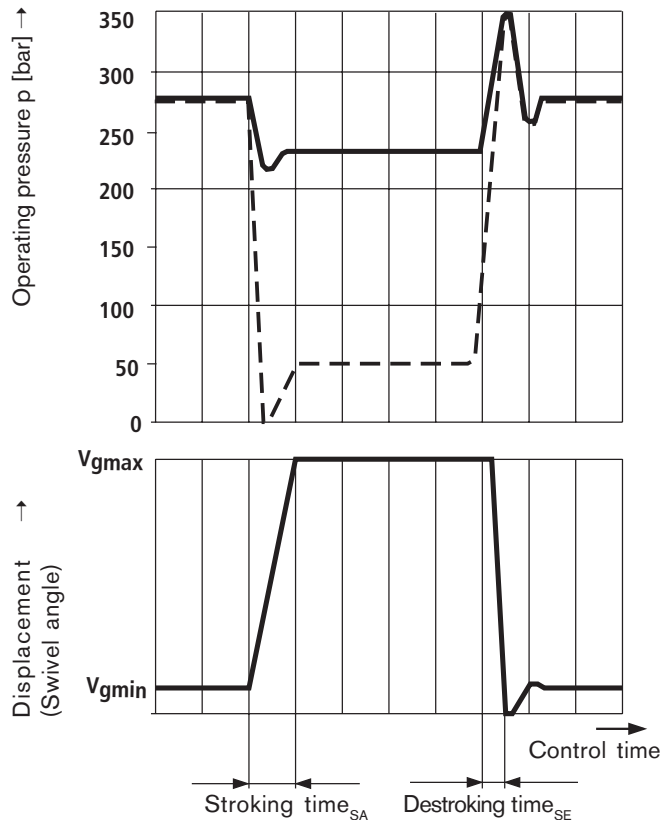

### Size 18...100

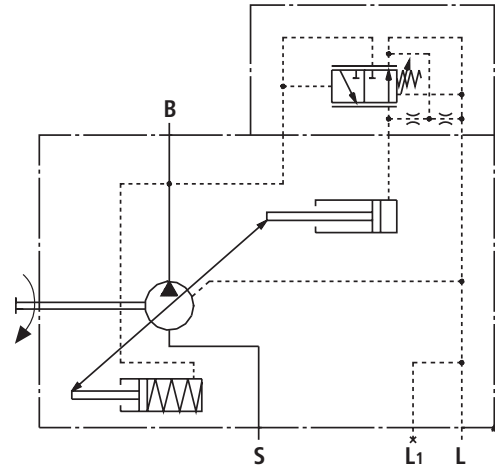

### Size 140

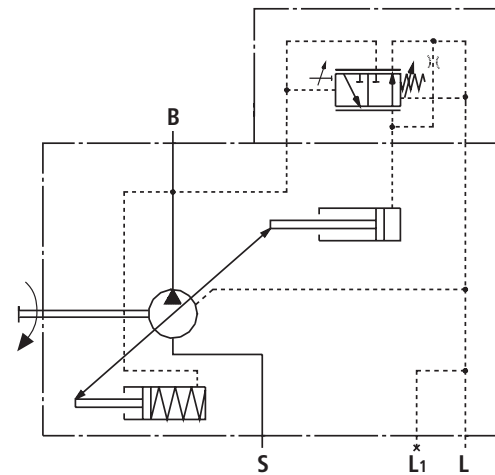

### Ports

- B Pressure port
- S Inlet port
- L, L1 Drain ports ( L1 closed)

### Control data

Hysteresis and repetitive accuracy  $\Delta p$  \_\_\_\_\_ max. 3 bar

### Pressure rise, max.

NG	18	28	45	71	100	140
$\Delta p$ bar	4	4	6	8	10	12

Pilot oil consumption \_\_\_\_\_ max. approx. 3 L/min

Flow loss at  $q_{vmax}$  see pages 8 and 9.

### Control time

NG	$t_{SA}$ [ms] against 50 bar	$t_{SA}$ [ms] against 220 bar	$t_{SE}$ [ms] Zero stroke 280 bar
18	50	25	20
28	60	30	20
45	80	40	20
71	100	50	25
100	125	90	30
140	130	110	30

# Unit dimensions DR

Before finalising your design please request a certified installation drawing. Subject to revision.

## Version 11N00 and 61 N00 - Ports at rear

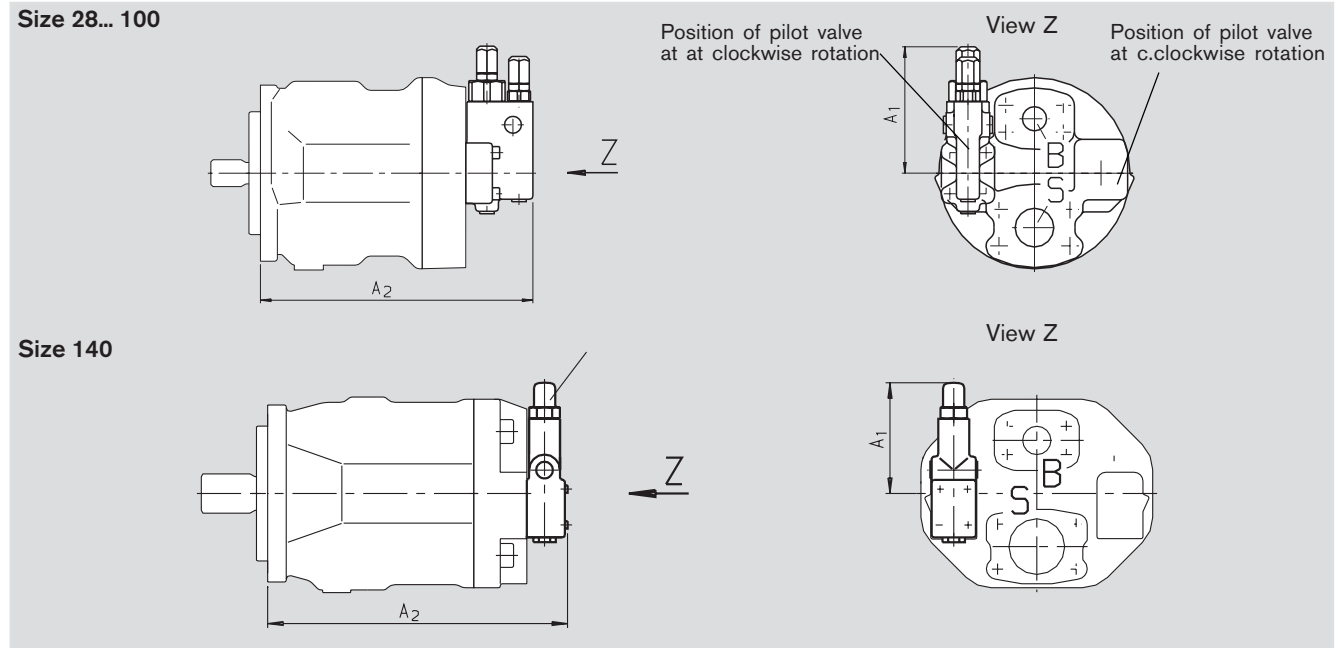

## Version 12 N00 and 62 N00 - Ports on side

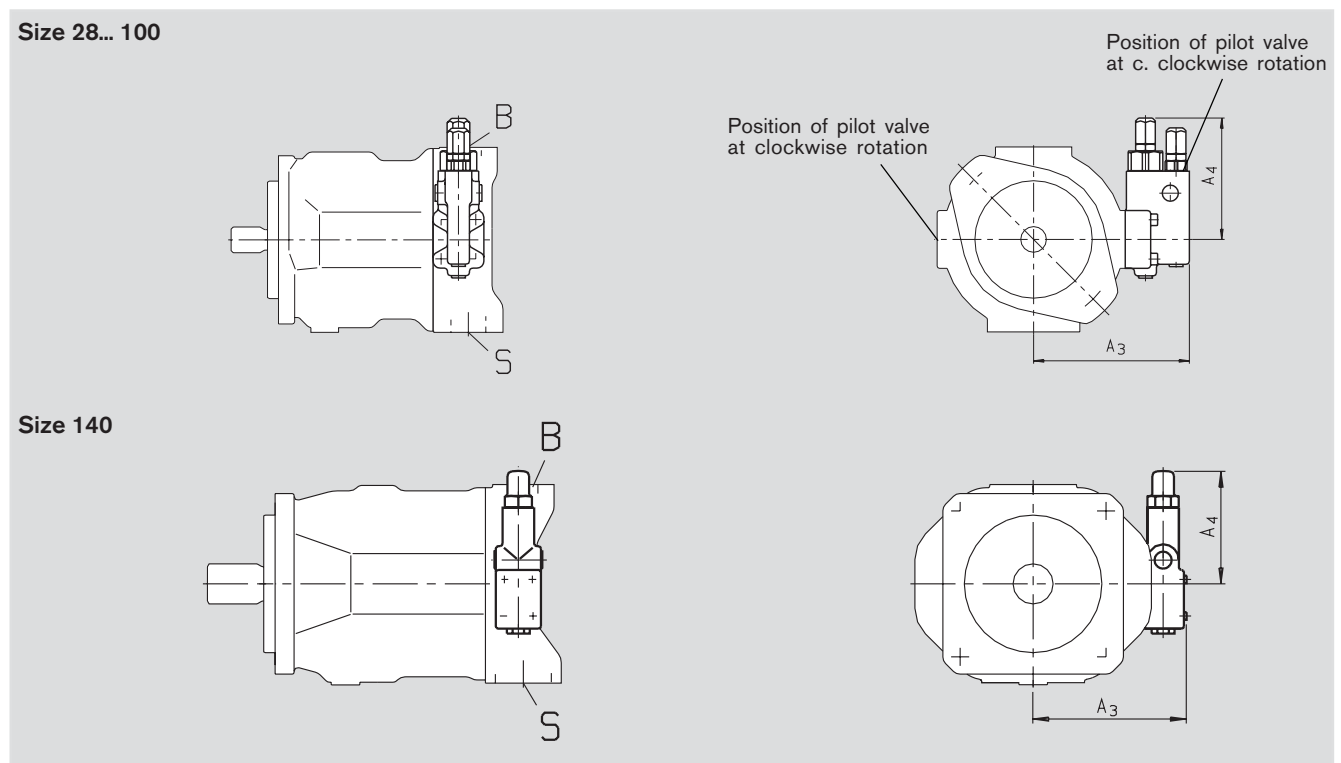

NG	A <sub>1</sub>	A <sub>2</sub>	A <sub>3</sub>	A <sub>4</sub>
18	-	-	126	105
28	109	225	136	106
45	106	244	146	106
71	106	278	160	106
100	106	344	165	106
140	127	339	169	127

for sizes 28 to 100 the DFR valve is used, whereby the flow control spool is locked at the factory and not tested

# DRG - Pressure control, remote

Function and design as for DR

A pressure relief valve may be externally piped to port X for remote control purposes. However it is not included in the scope of supply with the DRG control.

The differential pressure at the DRG control spool is set as standard to 20 bar and this results in a pilot flow of 1,5 L/min. If another setting is required, please state this in clear text.

We recommend that one of the following is used as the separate pressure relief valve:

DBDH 6 (hydraulic) to RE 25402 or

DBETR -SO 381 with orifice  $\varnothing 0,8$  in P (electrical) to RE29166.

Max. length of piping should not exceed 2m .

### Static characteristic

(at  $n_1 = 1500$  rpm;  $t_{oil} = 50^\circ C$ )

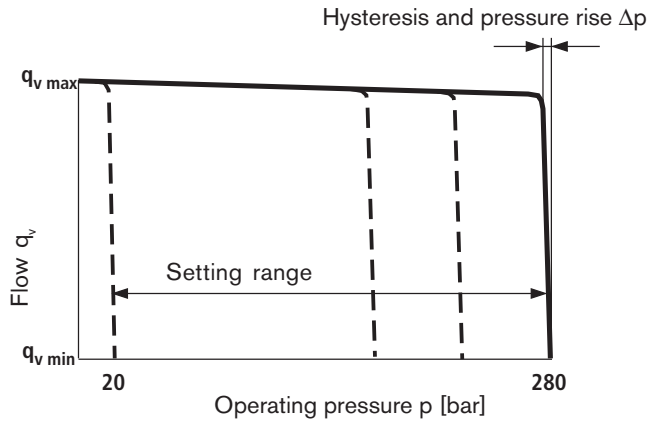

### Control data

Hysteresis  $\Delta p$  \_\_\_\_\_ max. 3 bar

### Pressure rise, max.

NG	18	28	45	71	100	140
$\Delta p$ bar	4	4	6	8	10	12

Pilot oil consumption \_\_\_\_\_ approx. 4,5 L/min

Flow loss at  $q_{vmax}$  see pages 8 and 9.

### Size 18...100

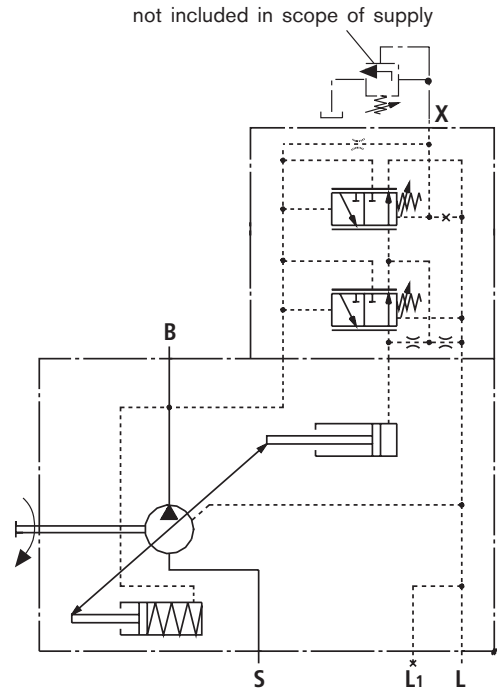

### Size 140

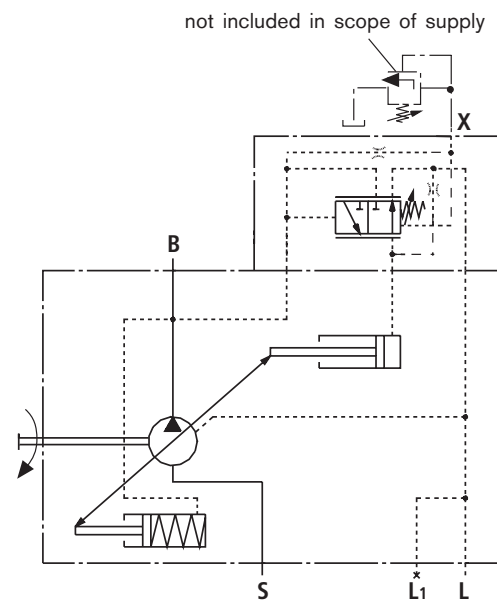

### Ports

- B Pressure port
- S Inlet port
- L, L1 Drain port ( L1 closed)
- X Pilot pressure port

Version	Size 18...100	Size 140
11 and 12	with Adapter	without Adapter
61 and 62	without Adapter	with Adapter

# Unit dimensions DRG

Before finalising your design please request a certified installation drawing. Subject to revision.

## Version 11 N00 and 61 N00 - Ports at rear

### Size 28... 100

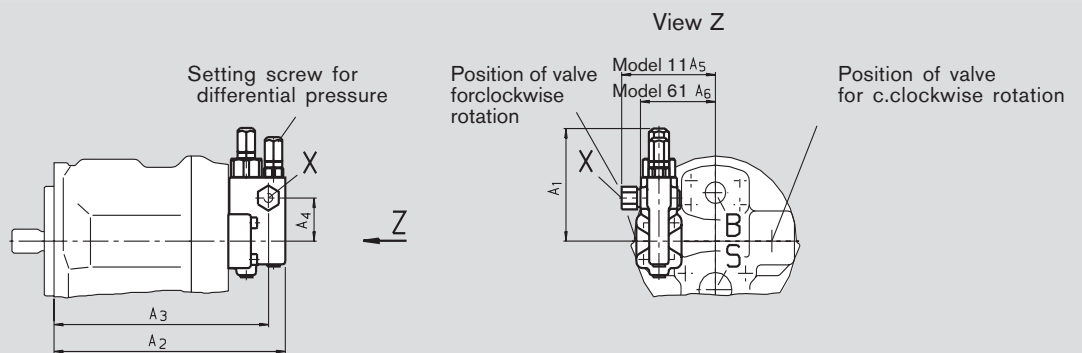

### Size 140

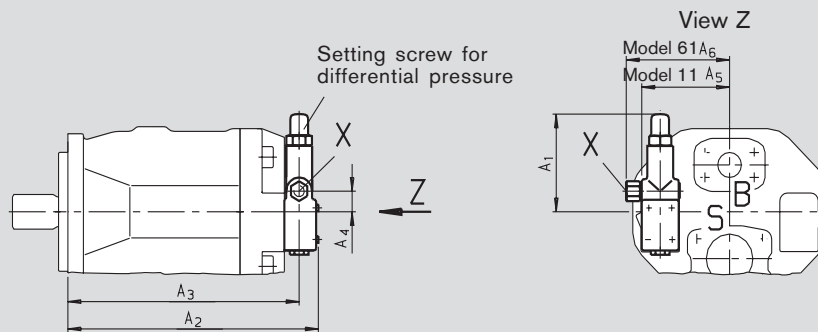

## Version 12 N00 and 62 N00 - Ports on side

### Size 18... 100

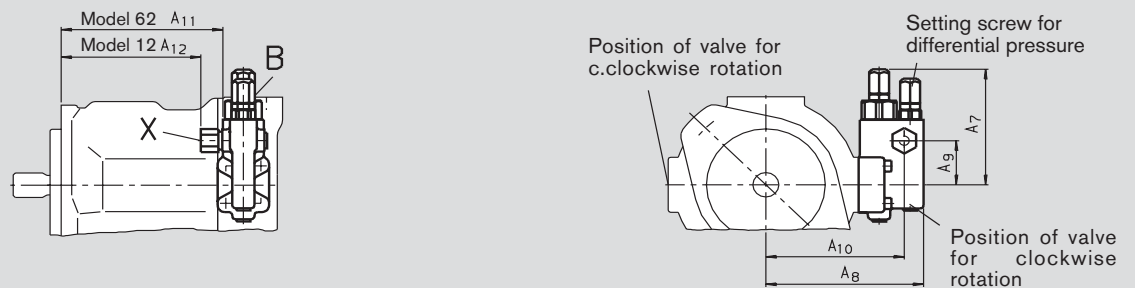

### Size 140

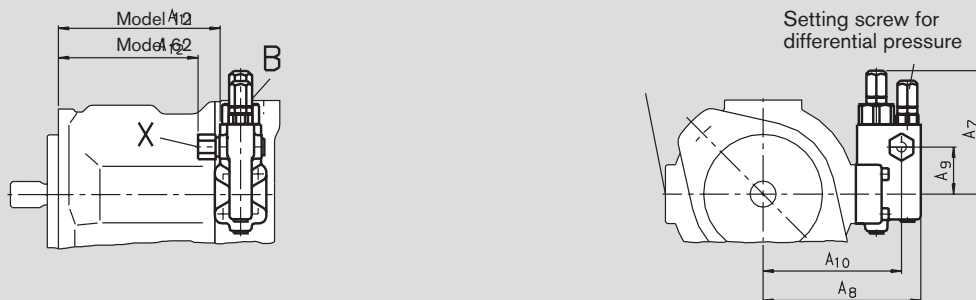

Size	A <sub>1</sub>	A <sub>2</sub>	A <sub>3</sub>	A <sub>4</sub>	A <sub>5</sub>	A <sub>6</sub>	A <sub>7</sub>	A <sub>8</sub>	A <sub>9</sub>	A <sub>10</sub>	A <sub>11</sub>	A <sub>12</sub>	Port X Models 61 and 62	Port X Models 11 and 12
18	-	-	-	-	-	-	105	126	40	109	130	109	7/16-20 UNF-2B; 10 deep	M14x1,5; 12 deep
28	109	225	209	43	94	73	106	136	40	119	140	119	7/16-20 UNF-2B; 10 deep	M14x1,5; 12 deep
45	106	244	228	40	102,5	81,5	106	146	40	129	155	134	7/16-20 UNF-2B; 10 deep	M14x1,5; 12 deep
71	106	278	262	40	112,5	91,5	106	160	40	143	183	162	7/16-20 UNF-2B; 10 deep	M14x1,5; 12 deep
100	106	344	327	40	120	99	106	165	40	148	250	229	7/16-20 UNF-2B; 10 deep	M14x1,5; 12 deep
140	127	339	313	27	118	140	127	169	27	143	222	244	9/16-18 UNF-2B; 13 deep	M14x1,5; 12 deep

# DFR/DFR1-Pressure-flow control

In addition to the pressure control function, the pump flow to the actuator may be varied by means of a differential pressure (eg. over an orifice or directional control valve). The pump supplies only the amount of fluid as required by the actuator.

In the DFR1-valve version the orifice between the X port and tank is plugged.

For function and content of pressure control see pages 18/19.

### Static characteristic

(at  $n_1 = 1500 \text{ rpm}$ ;  $t_{oil} = 50^\circ \text{ C}$ )

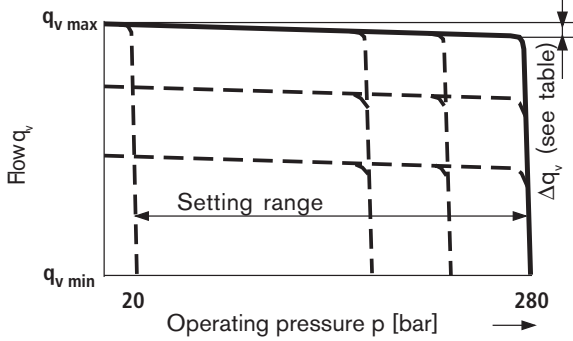

### Static characteristic at variable speed

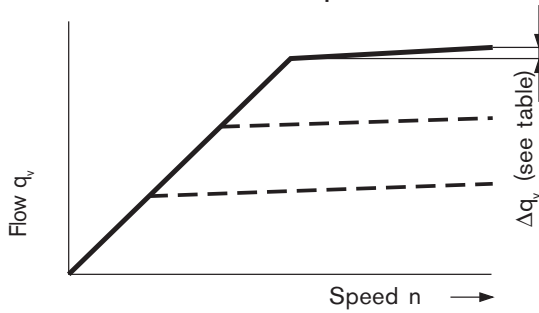

### Dynamic characteristic of flow control

The curves shown are measured average values under test conditions.

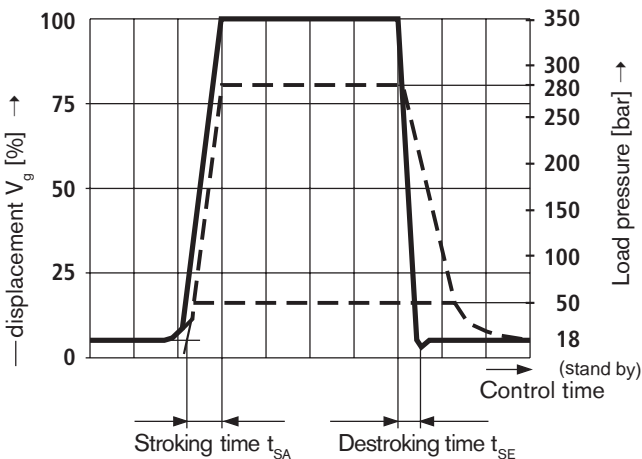

Size	$t_{SA}$ [ms] stand by-280 bar	$t_{SA}$ [ms] 280 bar stand by	$t_{SE}$ [ms] 50 bar stand by
18	40	15	40
28	40	20	40
45	50	25	50
71	60	30	60
100	120	60	120
140	130	60	130

### Size 18..100

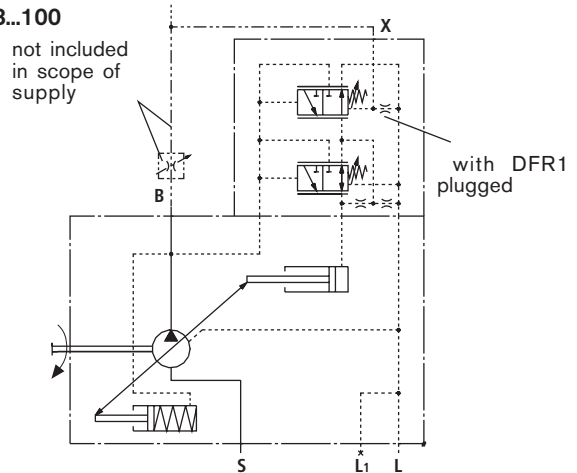

### Size 140

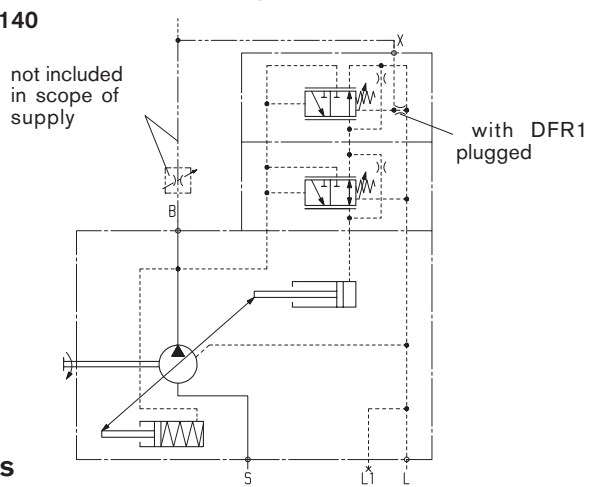

### Ports

- B Pressure port
- S Inlet port
- L, L1 Drain port ( L1 closed)
- X Pilot pressure port

Version	Size 18-100	Size 140
11 and 12	with Adapter	without Adapter
61 and 62	without Adapter	with Adapter

### Differential pressure $\Delta p$ :

Standard setting: 14 bar. If a different setting is required please state in clear text.

When port X is unloaded to tank (and outlet B is closed), a zero stroke pressure (standby) of  $p = 18 \pm 2 \text{ bar}$  results. (depends on  $\Delta p$ ).

### Control data

For technical data pressure control see page 18.

Max. flow deviation (Hysteresis and rise) measured at drive speed  $n = 1500 \text{ rpm}$

Size	18	28	45	71	100	140
$\Delta q_{Vmax}$ L/min	0,9	1,0	1,8	2,8	4,0	6,0



# Unit dimensions DFR/DFR1

Before finalising your design please request a certified installation drawing. Subject to revision.

## Version 11 N00 and 61 N00 - Ports at rear

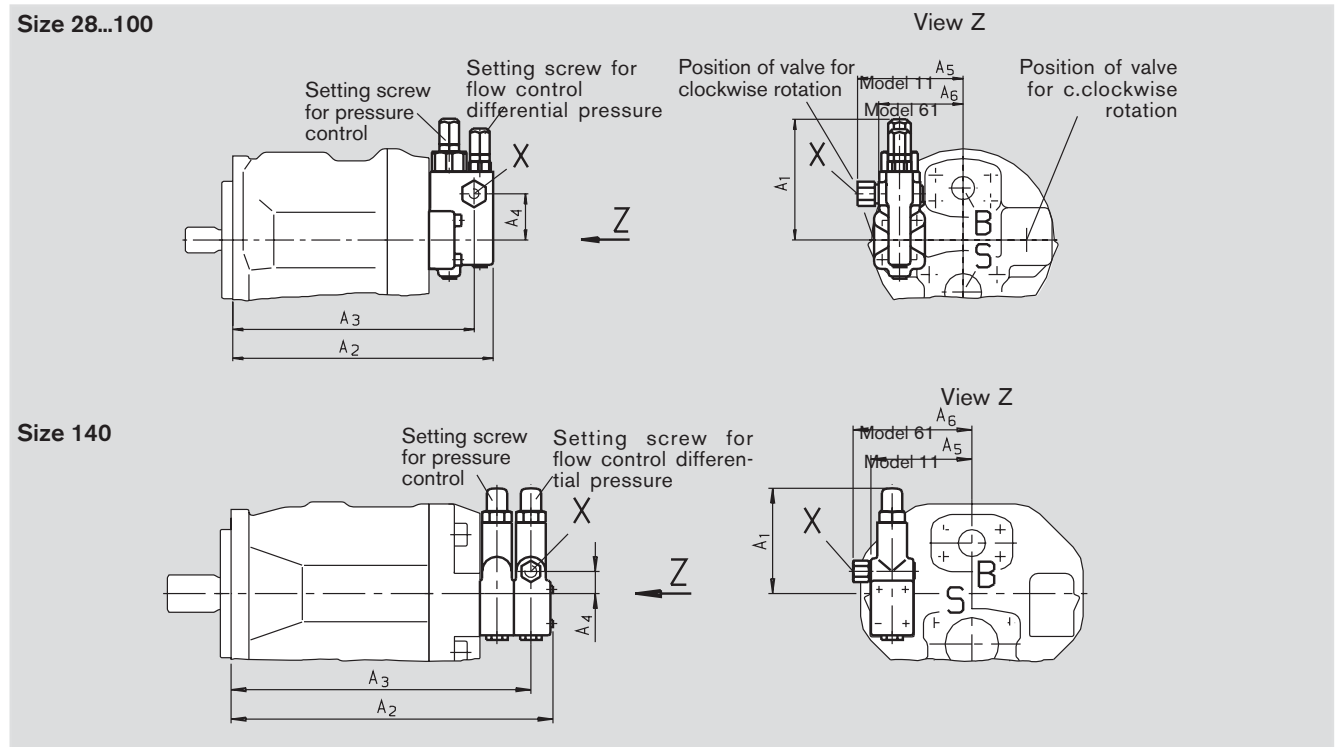

## Version 12 N00 and 62 N00 - Ports on side

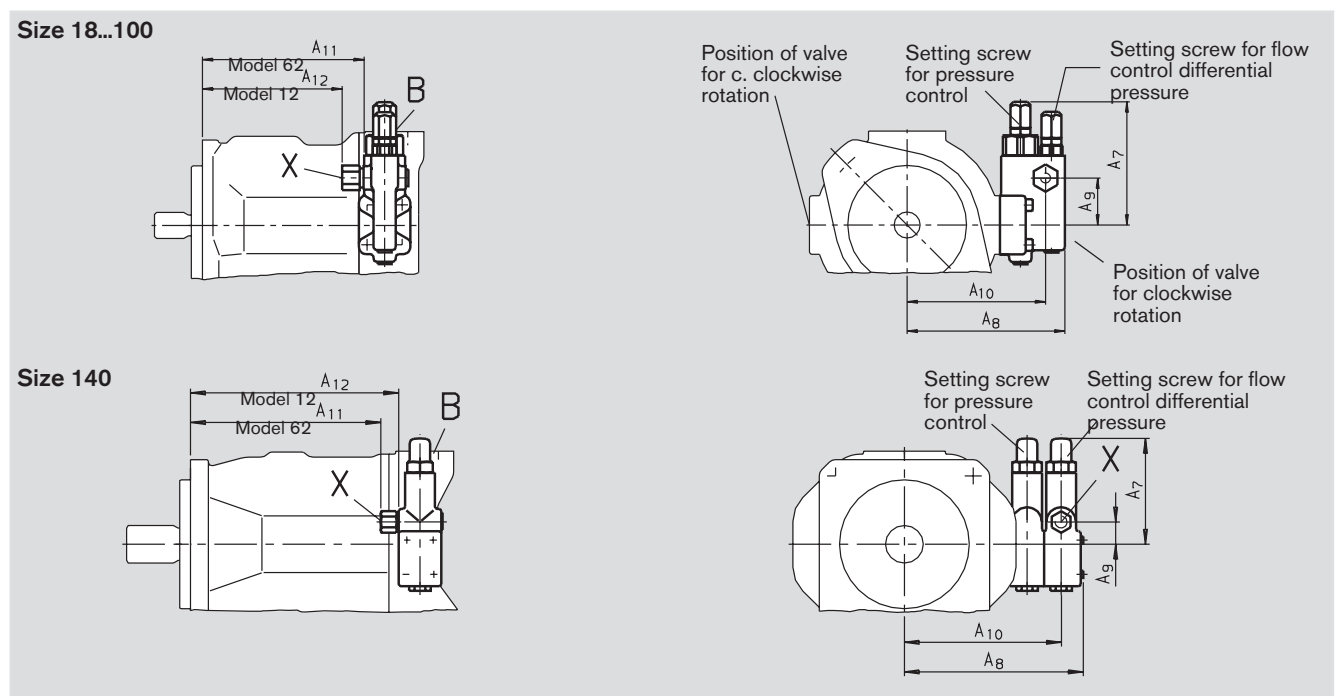

Size	A <sub>1</sub>	A <sub>2</sub>	A <sub>3</sub>	A <sub>4</sub>	A <sub>5</sub>	A <sub>6</sub>	A <sub>7</sub>	A <sub>8</sub>	A <sub>9</sub>	A <sub>10</sub>	A <sub>11</sub>	A <sub>12</sub>	Port X Models 61 and 62	Port X Models 11 and 12
18	-	-	-	-	-	-	105	126	40	109	130	109	7/16-20 UNF-2B; 10 deep	M14x1,5; 12 deep
28	109	225	209	43	94	73	106	136	40	119	140	119	7/16-20 UNF-2B; 10 deep	M14x1,5; 12 deep
45	106	244	228	40	102,5	81,5	106	146	40	129	155	134	7/16-20 UNF-2B; 10 deep	M14x1,5; 12 deep
71	106	278	262	40	112,5	91,5	106	160	40	143	183	162	7/16-20 UNF-2B; 10 deep	M14x1,5; 12 deep
100	106	344	327	40	120	99	106	165	40	148	250	229	7/16-20 UNF-2B; 10 deep	M14x1,5; 12 deep
140	127	379	353	27	118	140	127	209	27	183	222	244	9/16-18 UNF-2B; 13 deep	M14x1,5; 12 deep

# DFLR - Pressure/flow/power control

In order to achieve a constant drive torque with a varying operating pressure, the swivel angle and with it the output flow from the axial piston unit is varied so that the product of flow and pressure remains constant.

Flow control is possible below the limit of the power curve.

## Static characteristic

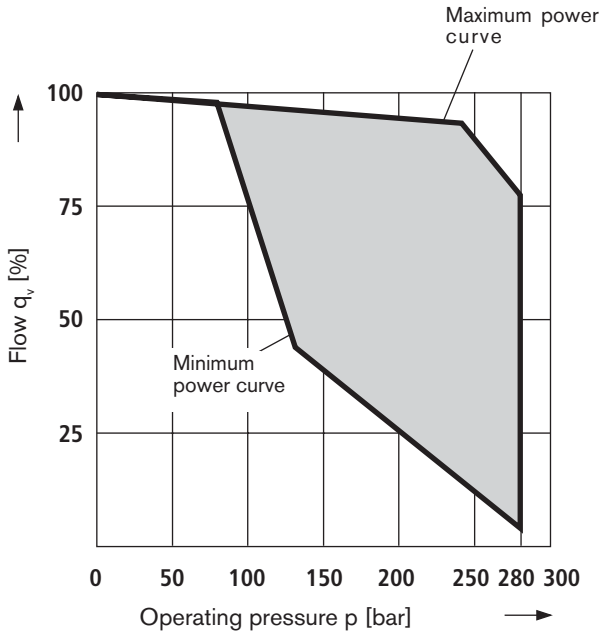

The power characteristic is factory-set so please enter details in clear ext, eg. 20 kW at 1500 rpm.

## Control data

For technical data pressure control see page 14.

For technical data flow control see page 16.

Start of control \_\_\_\_\_ from 80 bar

Pilot oil consumption \_\_\_\_\_ max. approx. 5,5 L/min

Flow loss at q<sub>vmax</sub> see page 8 and 9.

## Size 28... 100

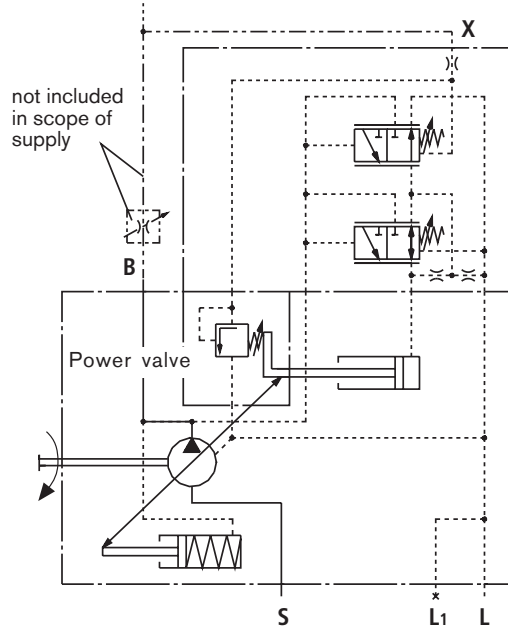

## Size 140

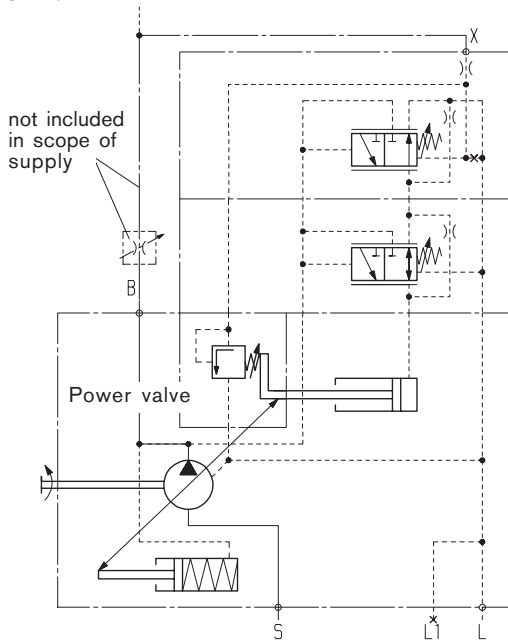

## Ports

- B** Pressure port
- S** Inlet port
- L, L1** Drain port (L1 closed)
- X** Pilot pressure port

# Unit dimensions DFLR

Before finalising your design please request a certified installation drawing. Subject to revision.

## Version 11N00 and 61 N00 - Ports at rear

### Size 28...100

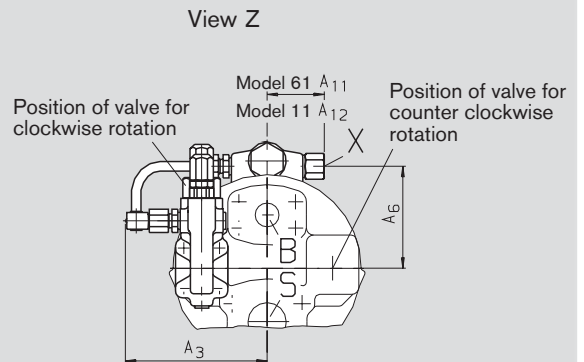
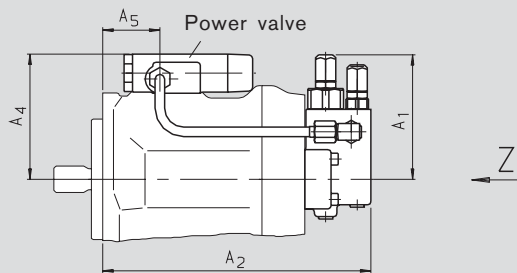

### Size 140

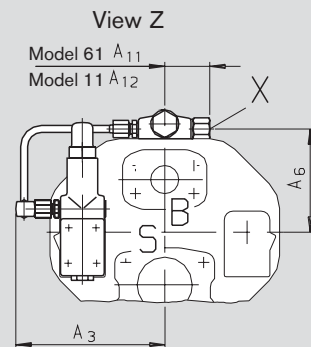
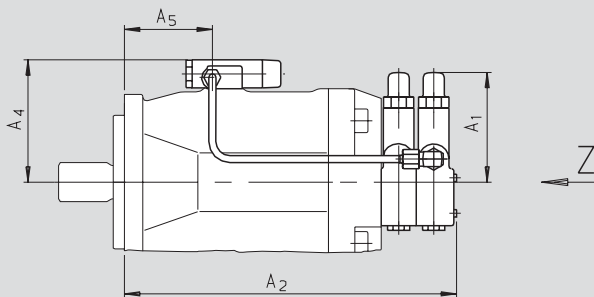

## Version 12N00 and 62 N00 - Ports on side

### Size 28...100

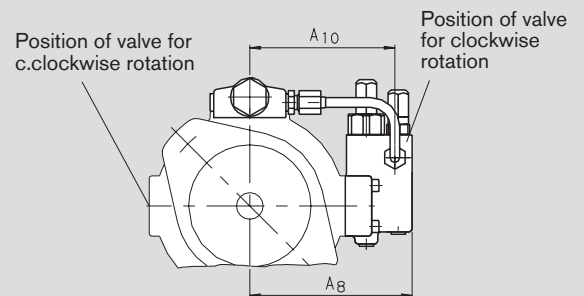
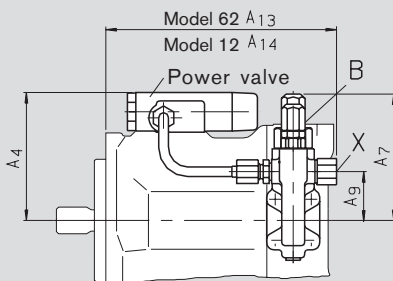

### Size 140

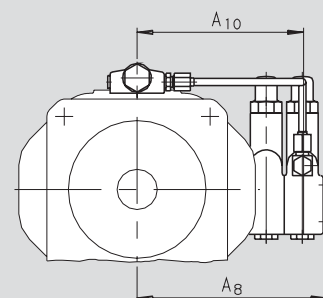
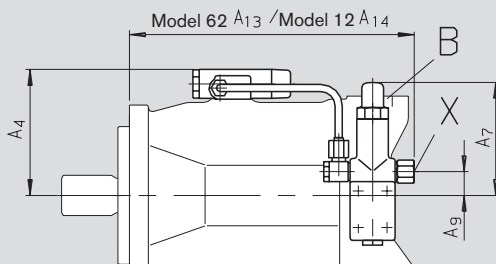

NG	A <sub>1</sub>	A <sub>2</sub>	A <sub>3</sub>	A <sub>4</sub>	A <sub>5</sub>	A <sub>6</sub>	A <sub>7</sub>	A <sub>8</sub>	A <sub>9</sub>	A <sub>10</sub>	A <sub>11</sub>	A <sub>12</sub>	A <sub>13</sub>	A <sub>14</sub>	Port X Models 61 and 62	Port X Models 11 and 12
28	109	225	120	107	48	86	106	136	40	119	48	51	194	197	7/16-20 UNF-2B; 10 deep	M14x1,5; 12 deep
45	106	244	129	112	54	91,5	106	146	40	129	48	51	209	212	7/16-20 UNF-2B; 10 deep	M14x1,5; 12 deep
71	106	278	139	124	69	103,5	106	160	40	143	48	51	237	240	7/16-20 UNF-2B; 10 deep	M14x1,5; 12 deep
100	106	344	145	129	111	108,5	106	165	40	148	48	51	304	307	7/16-20 UNF-2B; 10 deep	M14x1,5; 12 deep
140	127	379	148	140	99	123,5	127	209	26	183	48	51	314	314	7/16-20 UNF-2B; 10 t.(Mod.61)	M14x1,5;
140															9/16-18 UNF-2B; 13 t.(Mod.62)	

# FHD - Displacement control, pilot pressure dependent, with pressure control

The swivel angle of the pump, and hence the displacement or flow, is dependent on the pilot pressure  $p_{St\ x}$  in port X.

**Size 28...100**

A constant pressure  $p_y = 35$  bar is required at port Y.

An overriding pressure control is integrated, and can be steplessly set at the control valve

(Please state setting values in clear text).

### Control data

Hysteresis  $\pm 2\%$  of  $V_{g\ max}$

External Pilot oil consumption in Y\_\_max. approx. 3 ... 4,5 L/min

Pressure rise  $\Delta p$  \_\_\_\_\_ max. 4 bar

Min. system pressure  $p_{min}$  \_\_\_\_\_ 18 bar

Flow loss at  $q_{vmax}$  see pages 8 and 9.

### Static characteristic

(at  $n_1 = 1500$  rpm;  $t_{oil} = 50^\circ C$ )

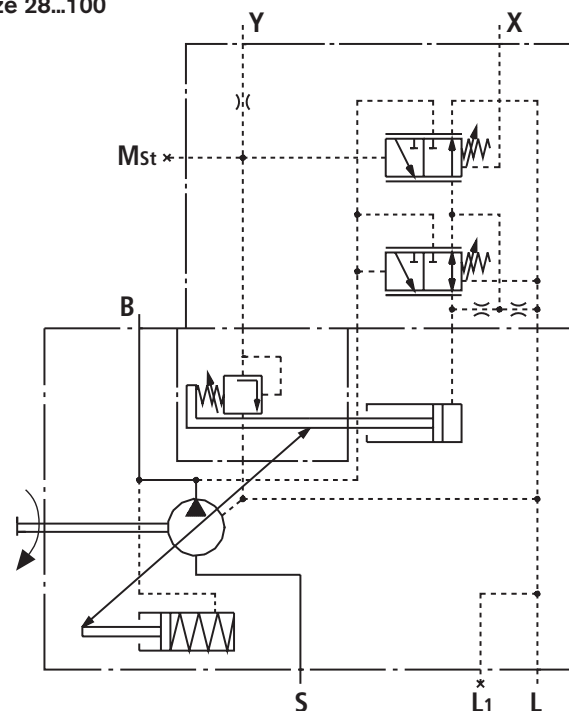
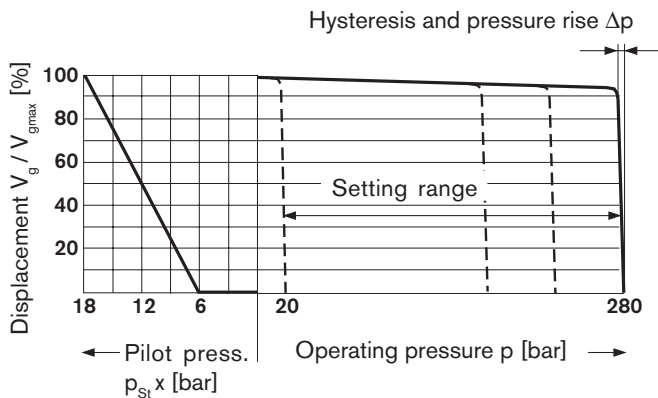

**Size 140**

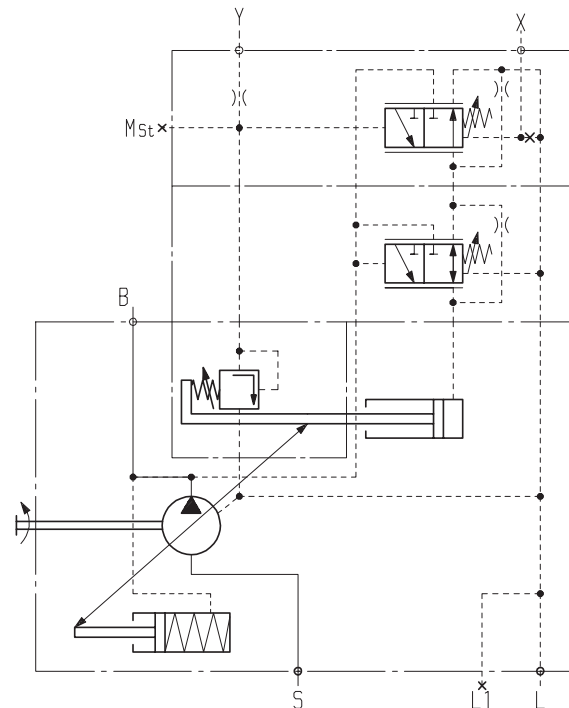

### Ports

- B** Pressure port
- S** Inlet port
- L, L1** Drain ports ( L1 closed)
- X, Y** Pilot pressure ports

# Unit dimensions FHD

Before finalising your design please request a certified installation drawing. Subject to revision.

## Version 11N00 - Ports at rear

Size 28... 100

On request

## Version 12N00 and 62 N00 -Ports on side

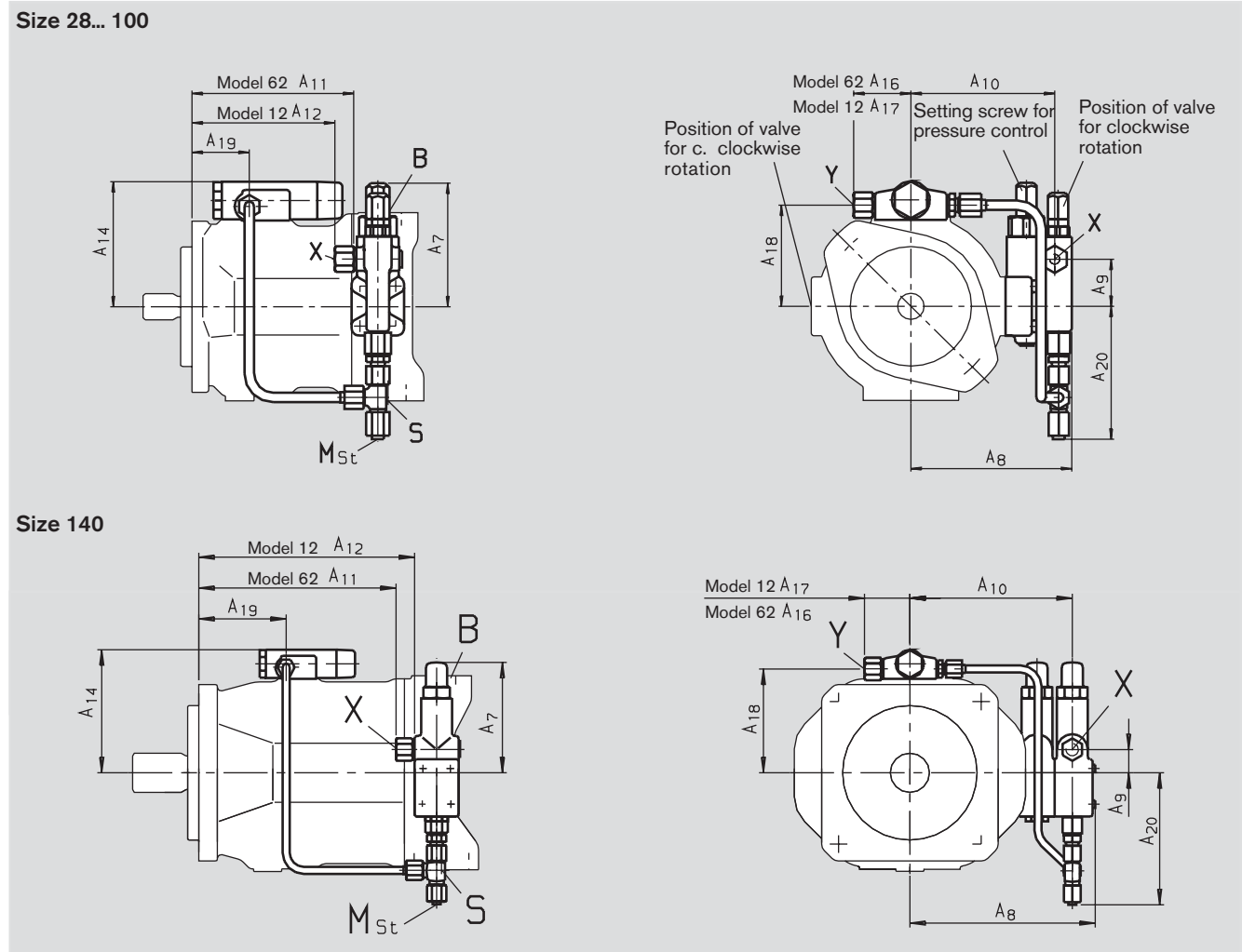

NG	A <sub>7</sub>	A <sub>8</sub>	A <sub>9</sub>	A <sub>10</sub>	A <sub>11</sub>	A <sub>12</sub>	A <sub>14</sub>	A <sub>16</sub>	A <sub>17</sub>	A <sub>18</sub>	A <sub>19</sub>	A <sub>20</sub>	Port X and Y	Port X and Y
28	106	136	40	119	140	119	107	48	51	86	48	113	7/16-20 UNF-2B; 10 deep	M14x1,5; 12 deep
45	106	146	40	129	155	134	112	48	51	91,5	54	113	7/16-20 UNF-2B; 10 deep	M14x1,5; 12 deep
71	106	160	40	143	183	162	124	48	51	103,5	69	113	7/16-20 UNF-2B; 10 deep	M14x1,5; 12 deep
100	106	165	40	148	250	229	129	48	51	108,5	111	113	7/16-20 UNF-2B; 10 deep	M14x1,5; 12deep
140	127	209	27	183	222	244	140	48	51	119	99	150	7/16-20 UNF-2B; 10 t.(X)	M14x1,5;
140													9/16-18 UNF-2B; 13 t.(Y)	

# Unit dimensions, Size 18

Before finalising your design please request a certified installation drawing.

## Version 12 N00

Service ports on side, no through drive (without control valves)

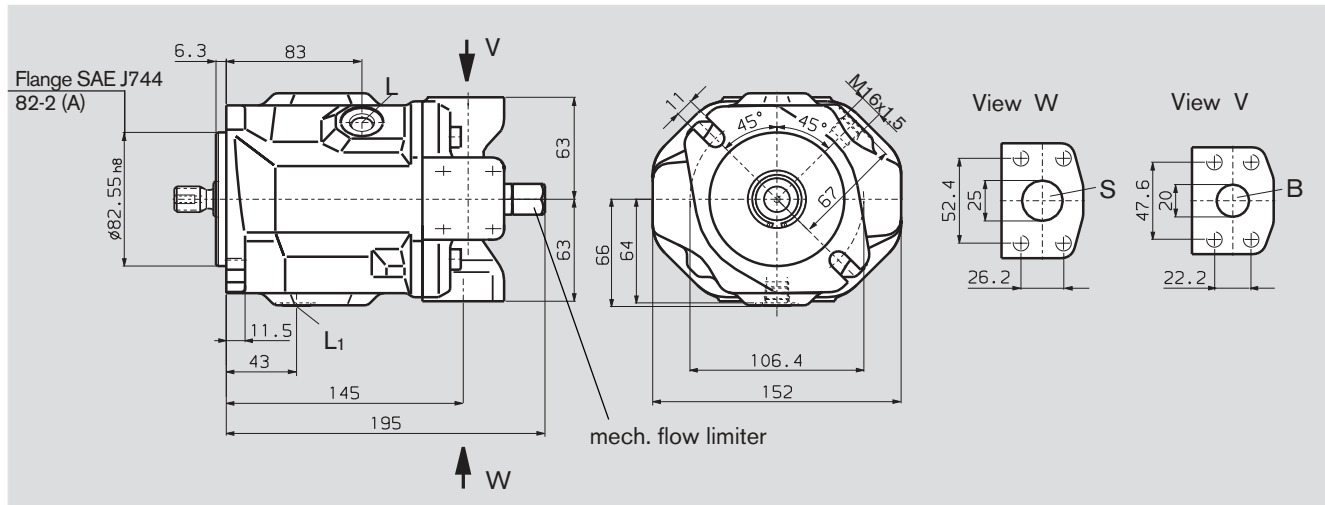

## Shaft ends (acc. to SAE J744 OCT83)

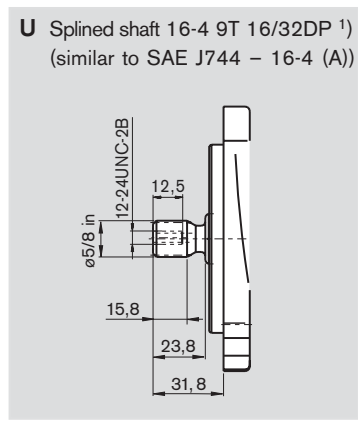
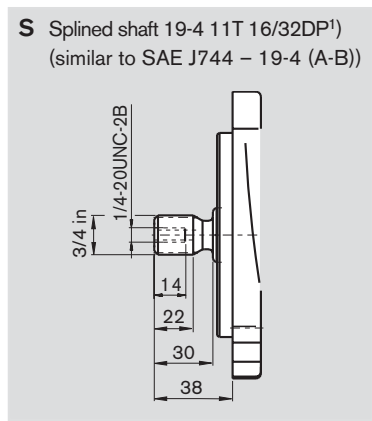

## Ports

Port	Description	Thread	Size	Tightening torques, max. <sup>2)</sup>
B	Pressure port (Standard pressure range)	SAE J518	3/4 in	60 Nm
	Fixing thread	DIN 13	M10x1,5; 17deep	
S	Inlet port (Standard pressure range)	SAE J518	1 in	60 Nm
	Fixing thread	DIN 13	M10x1,5; 17 deep	
L, L <sub>1</sub>	Drain ports	DIN 3852-1	M16x1,5	100 Nm

<sup>1)</sup> ANSI B92.1a-1976, 30° pressure angle, flat base, flank centering, fit class 5

<sup>2)</sup> See safety information

# Unit dimensions, Size 18

Before finalising your design please request a certified installation drawing.

## Version 62 N00

Service ports on side, no through drive (without control valves)

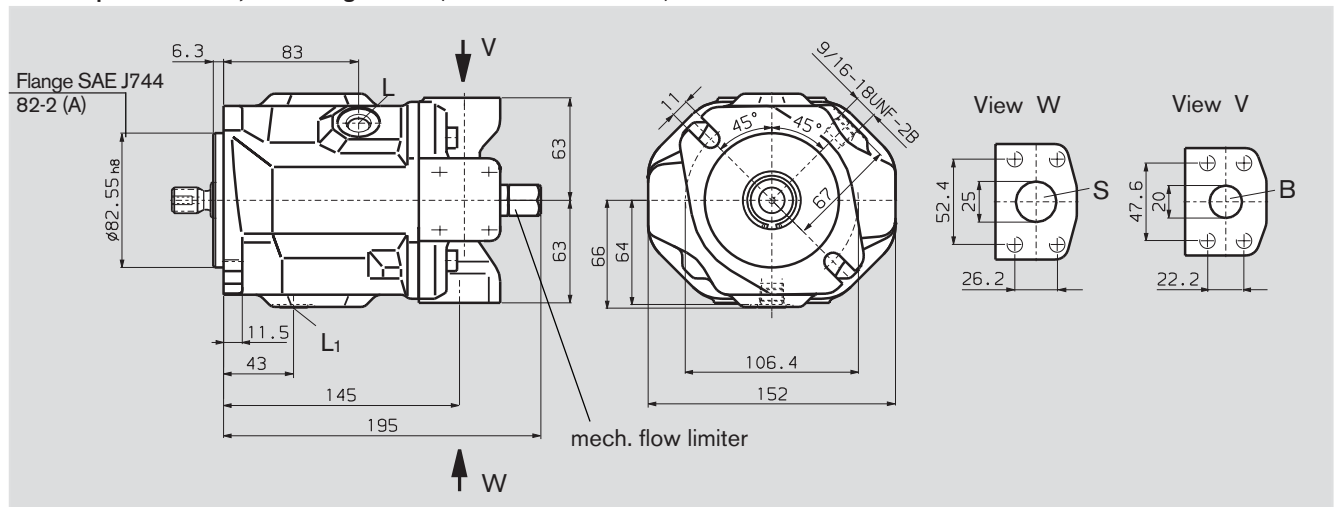

### Ports

B	Pressure port (Standard pressure range)	SAE J518	3/4 in	40 Nm
	Fixing thread		3/8-16UNC-2B; 20 deep	
S	Inlet port (Standard pressure range)	SAE J518	1 in	40 Nm
	Fixing thread		3/8-16UNC-2B; 20 deep	
L, L <sub>1</sub>	Drain ports	DIN 11926	9/16-18UNF-2B	80 Nm

<sup>1)</sup> See safety information

Tightening torques, max. <sup>1)</sup>

# Unit dimensions, size 28

Before finalising your design please request a certified installation drawing.

## Version 11 N00

Ports at rear, no through drive (without control valves)

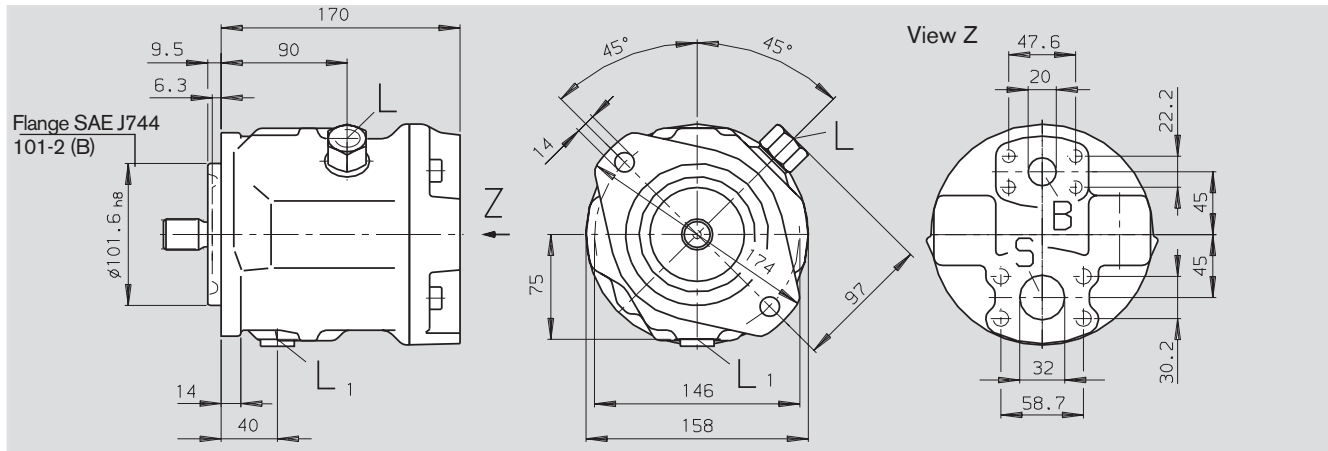

## Version 12 N00

Ports on side, no through drive

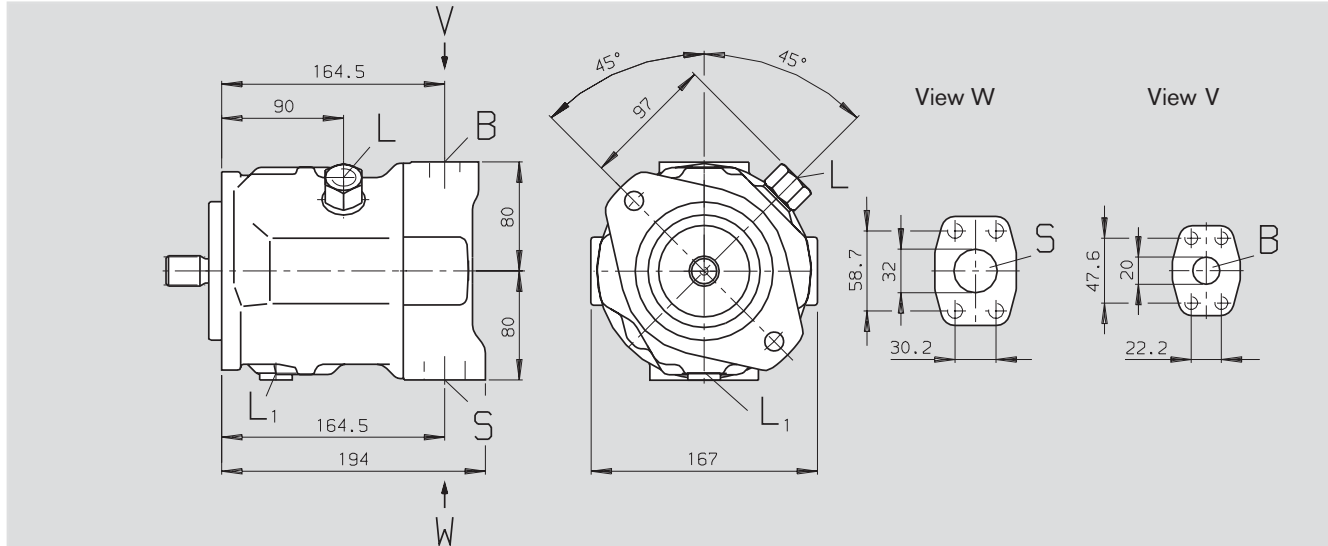

## Shaft ends (acc. to SAE J744 OCT83)

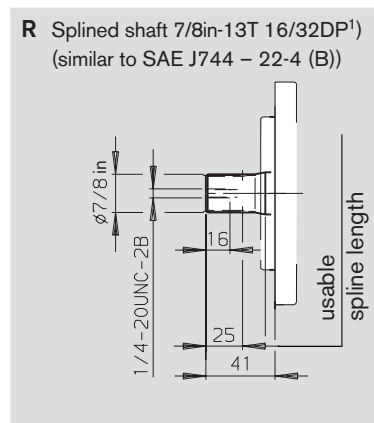
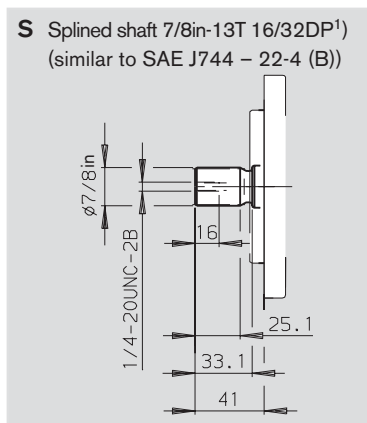

## Ports

Port	Description	SAE	Size	Tightening torques, max. <sup>2)</sup>
B	Pressure port (Standard pressure range)	SAE J518	3/4 in	60 Nm
	Fixing thread	DIN 13	M10x1,5; 17 deep	
S	Inlet port (Standard pressure range)	SAE J518	1 1/4 in	60 Nm
	fixing thread	DIN 13	M10x1,5; 17 deep	
L	Drain port	DIN 3852-1	M18x1,5;	140 Nm
L <sub>1</sub>	Drain port (closed)	ISO 11926	3/4-16 UNF-2B	160 Nm

<sup>1)</sup> ANSI B92.1a-1976, 30° pressure angle, flat base, flank centering, fit class 5

<sup>2)</sup> See safety information



# Unit dimensions, size 28

Before finalising your design please request a certified installation drawing.

## Version 61 N00

Ports at rear, no through drive (without control valves)

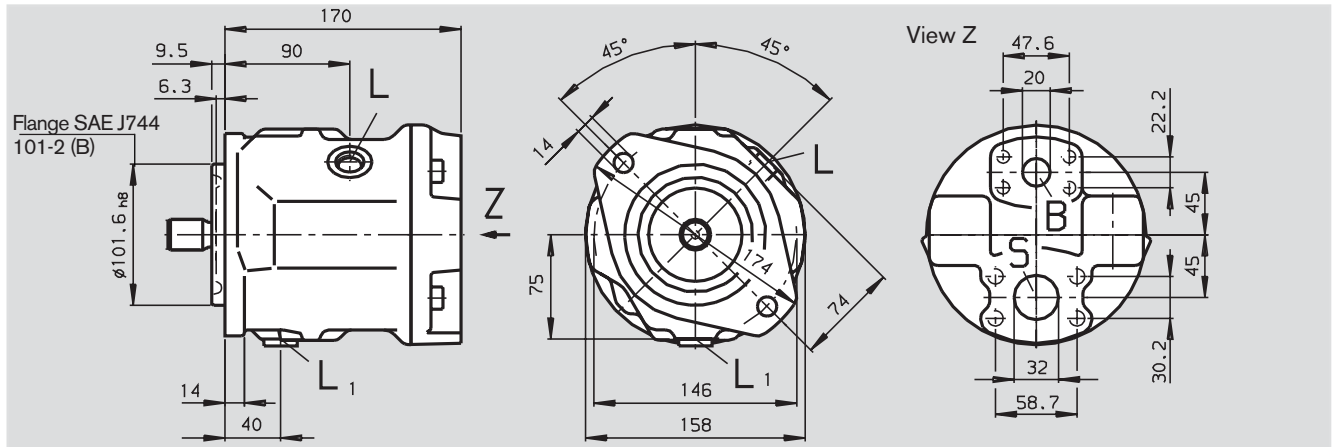

## Version 62 N00

Ports on side, no through drive

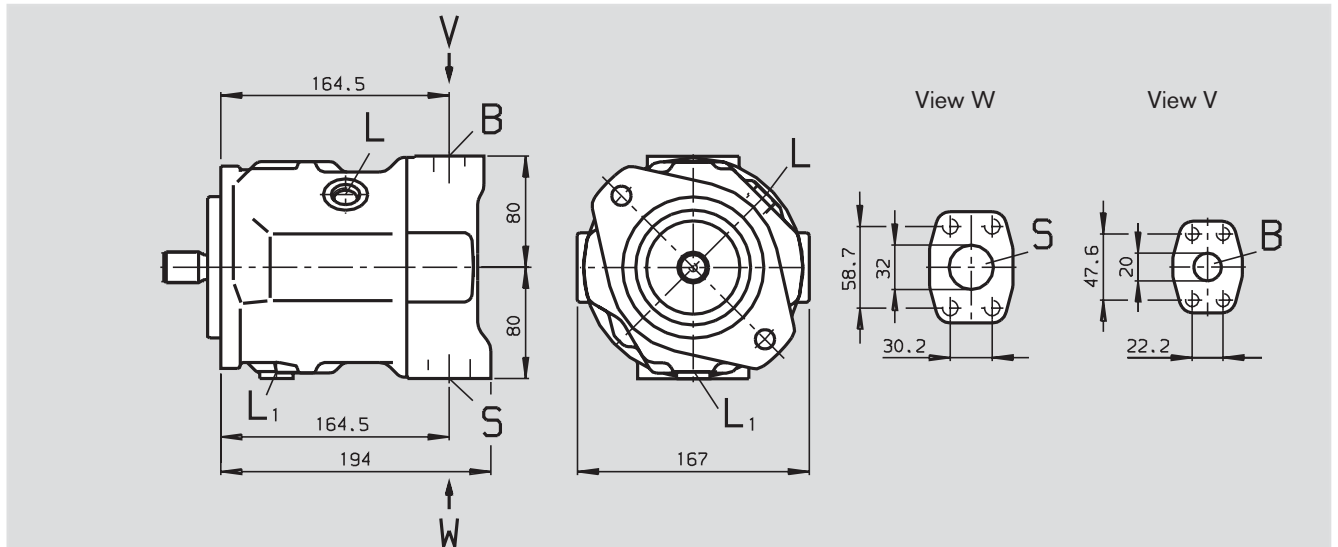

### Ports

B	Pressure port (Standard pressure range)	SAE J518	3/4 in	Tightening torques, max. <sup>1)</sup>
	Fixing thread		3/8-16UNC-2B; 18 deep	
S	Inlet port (Standard pressure range)	SAE J518	1 1/4 in	Tightening torques, max. <sup>1)</sup>
	fixing thread		7/16-14UNC-2B; 24 deep	
L, L <sub>1</sub>	Drain ports (L <sub>1</sub> closed)	ISO 11926	3/4-16 UNF-2B	160 Nm

<sup>1)</sup> See safety information

# Unit dimensions size 45

Before finalising your design please request a certified installation drawing.

## Version 11 N00

Ports at rear, no through drive (without control valves)

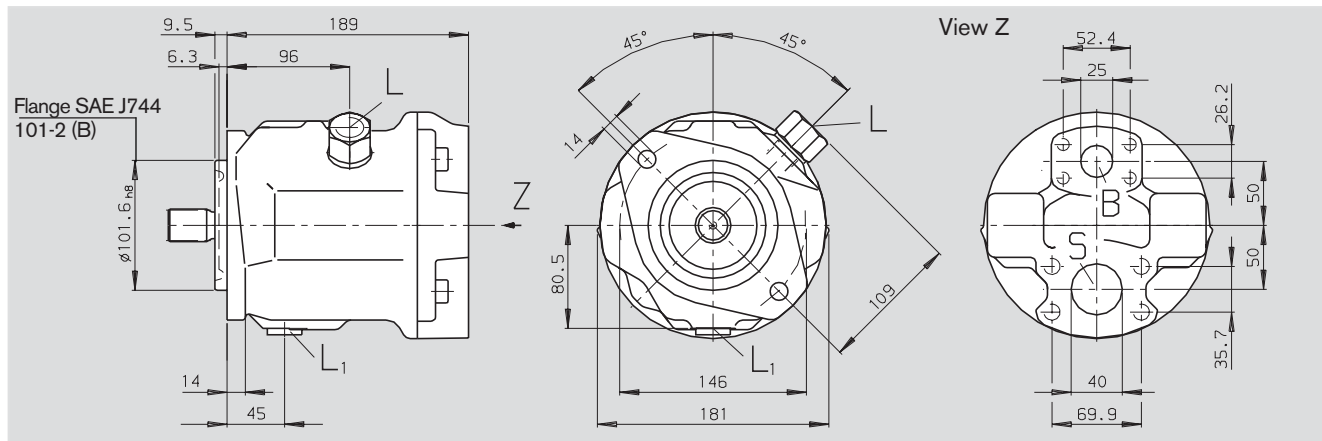

## Version 12 N00

Ports on side, no through drive

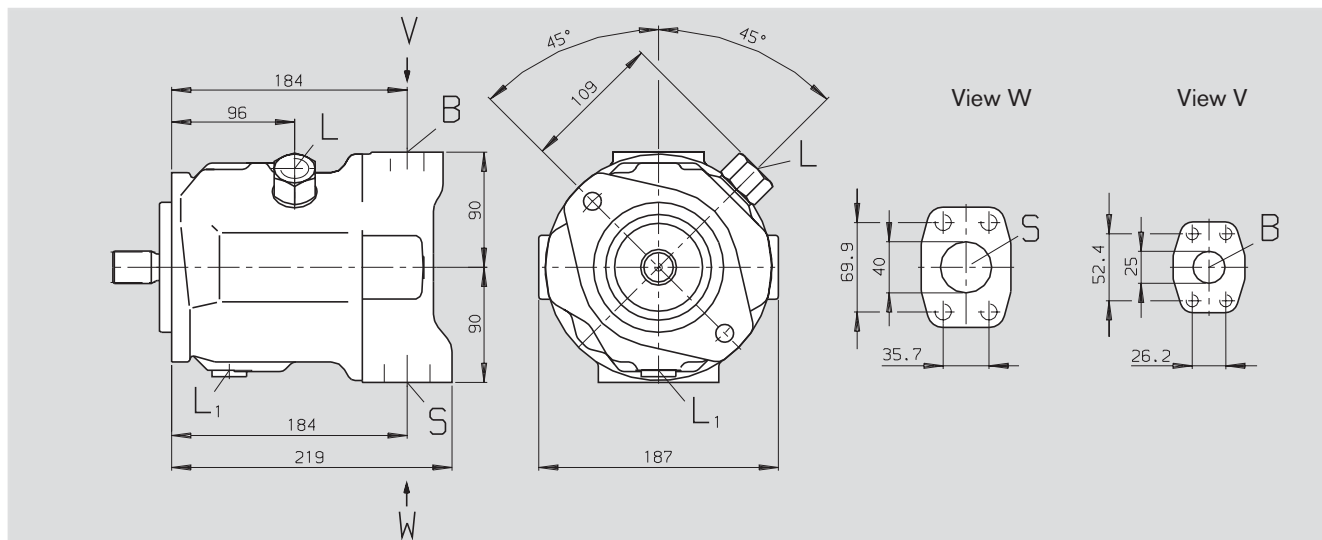

## Shaft ends (acc.to SAE J744 OCT83)

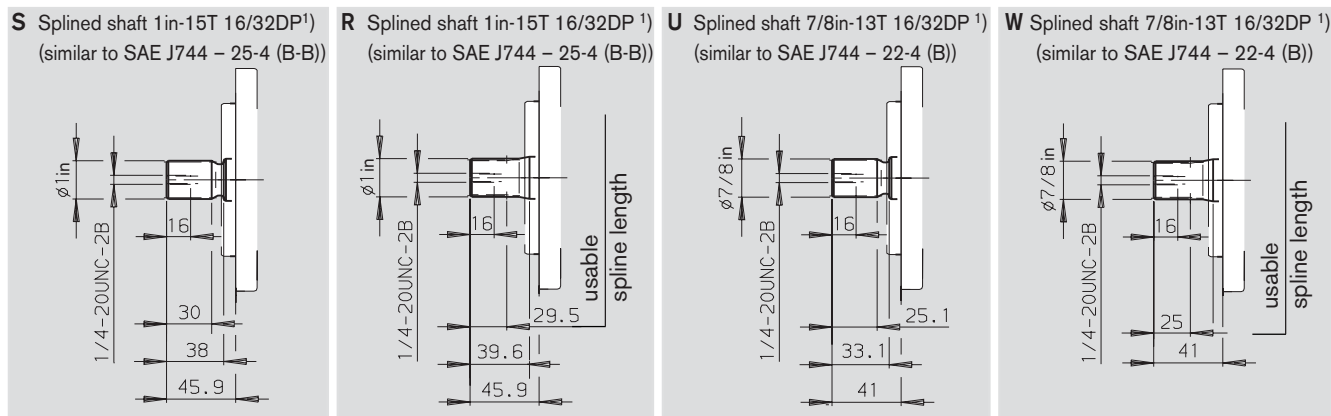

## Ports

Port	Description	Standard	Size	Tightening torques, max. <sup>2)</sup>
B	Pressure port (Standard pressure range)	SAE J518	1 in	60 Nm
	Fixing thread	DIN 13	M10x1,5; 17 deep	
S	Inlet port (Standard pressure range)	SAE J518	1 1/2 in	130 Nm
	Fixing thread	DIN 13	M12x1,75; 20 deep	
L	Drain port	DIN 3852-1	M22x1,5	210 Nm
L <sub>1</sub>	Drain port (closed)	ISO 11926	7/8-14 UNF-2B	240 Nm

<sup>1)</sup> ANSI B92.1a-1976, 30° pressure angle, flat base, flange centering, fit class 5

<sup>2)</sup> See safety information

# Unit dimensions size 45

Before finalising your design please request a certified installation drawing.

## Version 61 N00

Ports at rear, no through drive (without control valves)

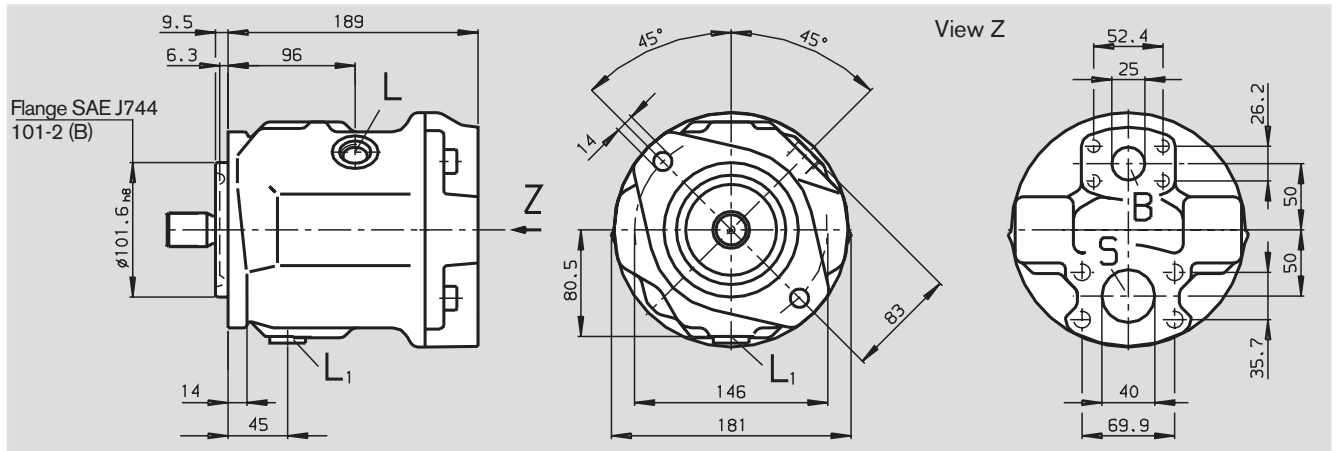

## Version 62 N00

Ports on side, no through drive

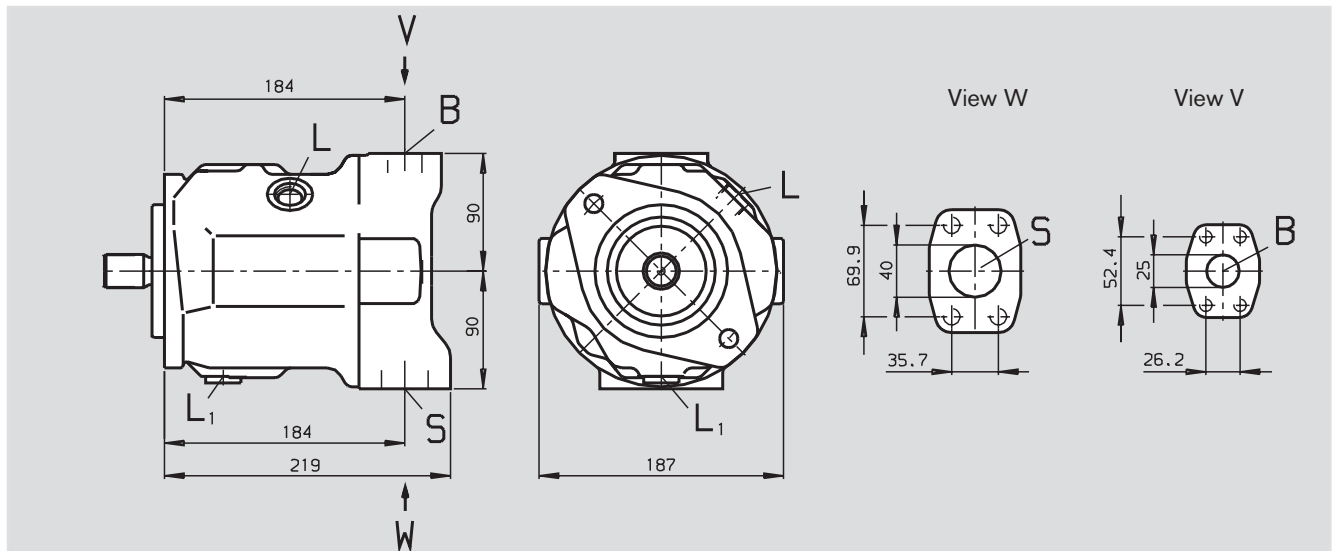

### Ports

B	Pressure port (Standard pressure range)	SAE J518	1 in
	Fixing thread		3/8-16UNC-2B; 18 deep
S	Inlet port (Standard pressure range)	SAE J518	1 1/2 in
	Fixing thread		1/2-13UNC-2B; 22 deep
L, L <sub>1</sub>	Drain ports (L <sub>1</sub> closed)	ISO 11926	7/8-14 UNF-2B

<sup>1)</sup> See safety information

### Tightening torques, max. <sup>1)</sup>

40 Nm
90 Nm
240 Nm

# Unit dimensions size 71

Before finalising your design please request a certified installation drawing.

## Version 11 N00

Ports at rear, no through drive (without control valves)

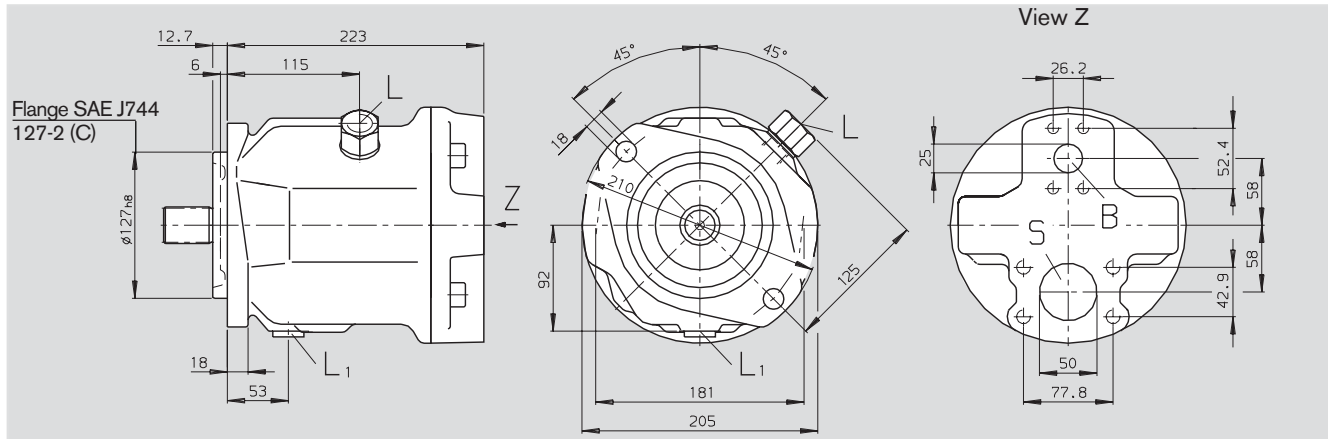

## Version 12 N00

Ports on side, no through drive

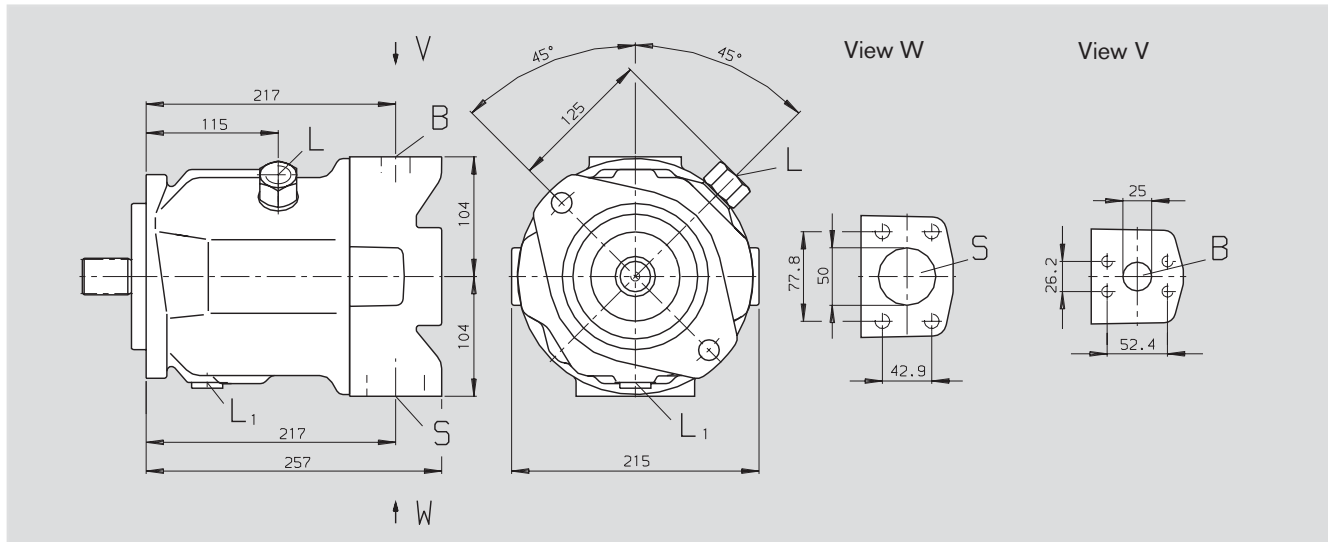

## Shaft ends (acc. to SAE J744 OCT83)

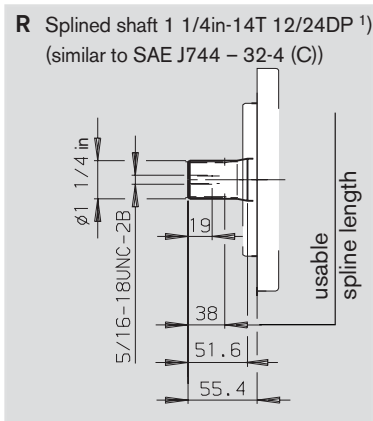
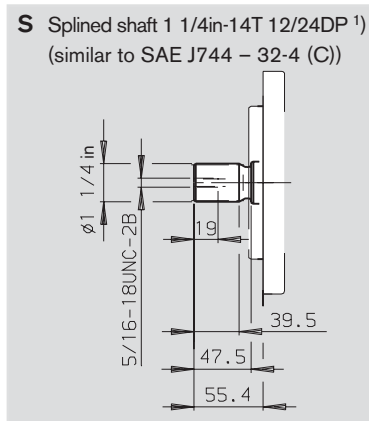

## Ports

B	Pressure port (Standard pressure range)	SAE J518	1 in
	Fixing thread	DIN 13	M10x1,5; 17 deep
S	Inlet port (Standard pressure range)	SAE J518	2 in
	Fixing thread	DIN 13	M12x1,75; 22 deep
L	Drain port	DIN 3852-1	M22x1,5
$L_1$	Drain port (closed)	ISO 11926	7/8-14 UNF-2B

## Tightening torques, max. <sup>2)</sup>

60 Nm
130 Nm
210 Nm
240 Nm

<sup>1)</sup> ANSI B92.1a-1976, 30° pressure angle, flat base, flank centering, fit class 5

<sup>2)</sup> See safety information

# Unit dimensions size 71

Before finalising your design please request a certified installation drawing.

## Version 61 N00

Ports at rear, no through drive (without control valves)

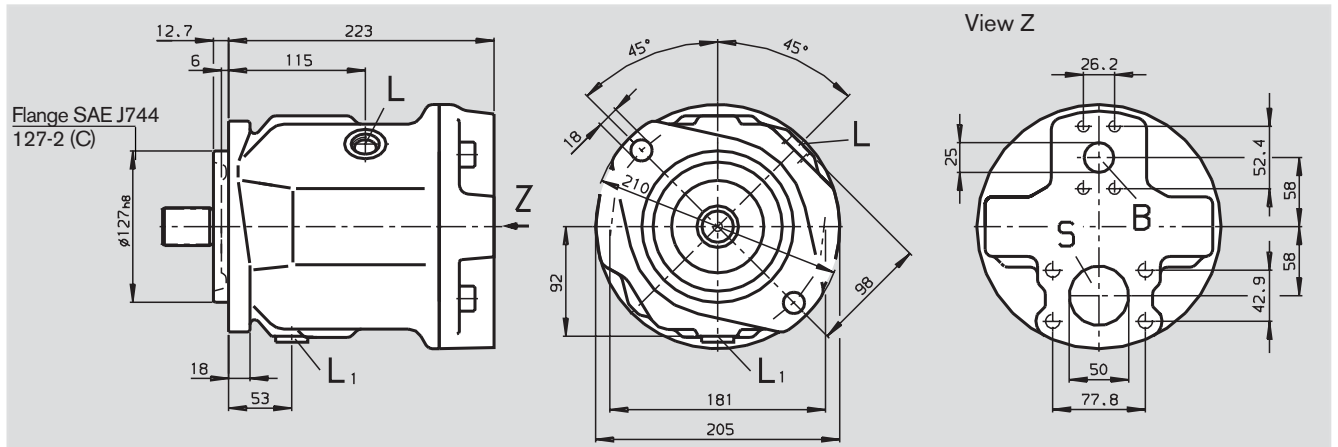

## Version 62 N00

Ports on side, no through drive

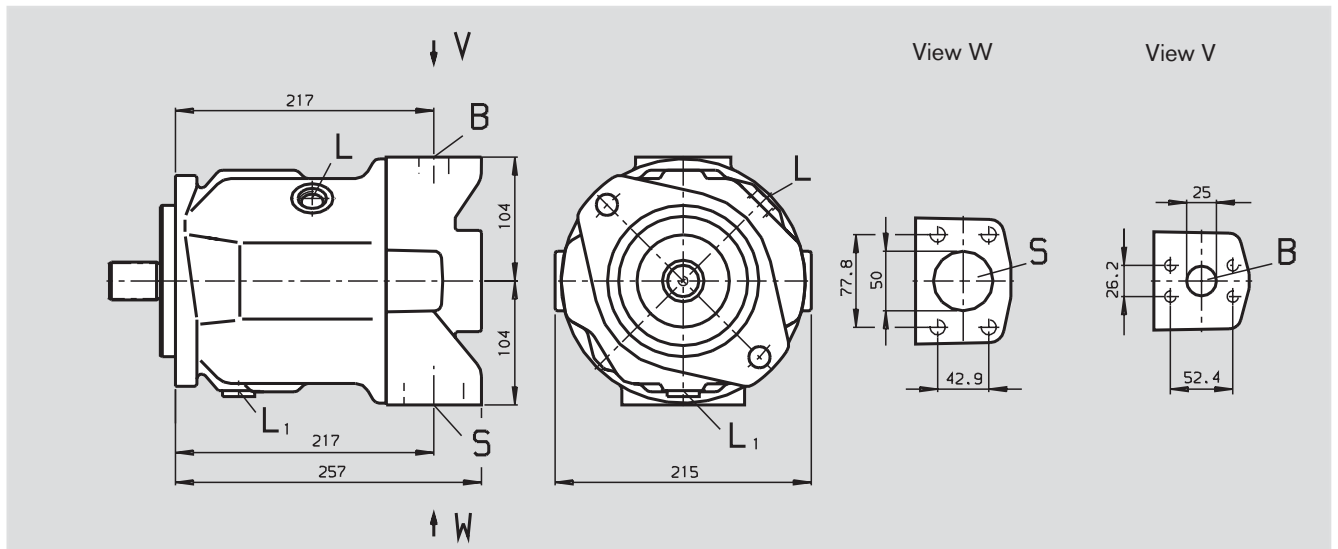

### Ports

B	Pressure port (Standard pressure range)	SAE J518	1 in
	Fixing thread		3/8-16UNC-2B; 18 deep
S	Inlet port (Standard pressure range)	SAE J518	2 in
	Fixing thread		1/2-13UNC-2B; 22 deep
L, L <sub>1</sub>	Drain ports (L <sub>1</sub> closed)	ISO 11926	7/8-14 UNF-2B

<sup>1)</sup> See safety information

### Tightening torques, max. <sup>1)</sup>

40 Nm
90 Nm
240 Nm

# Unit dimensions size 100

Before finalising your design please request a certified installation drawing.

## Version 11 N00

Ports at rear, no through drive (without control valves)

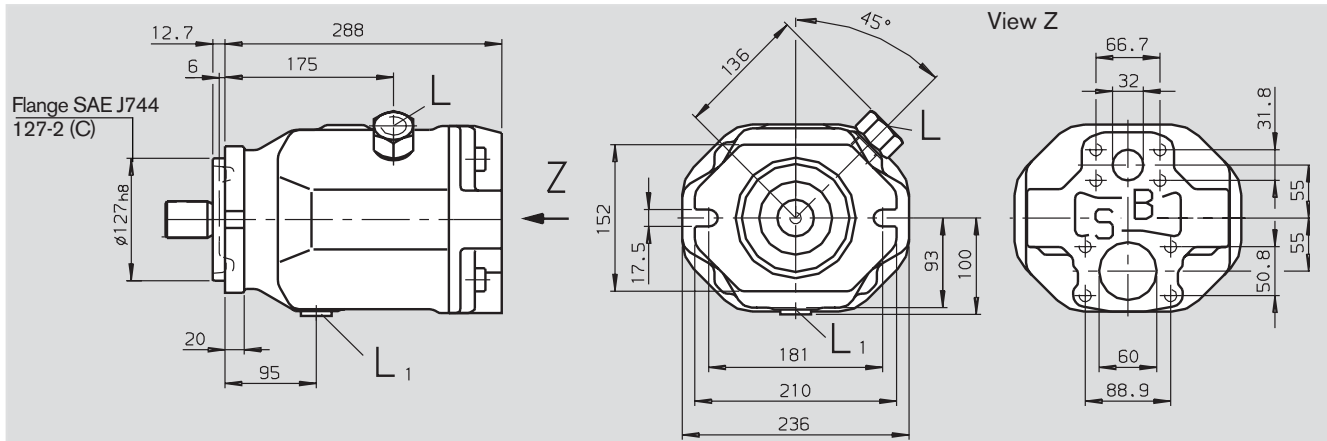

## Version 12 N00

Ports on side, no through drive

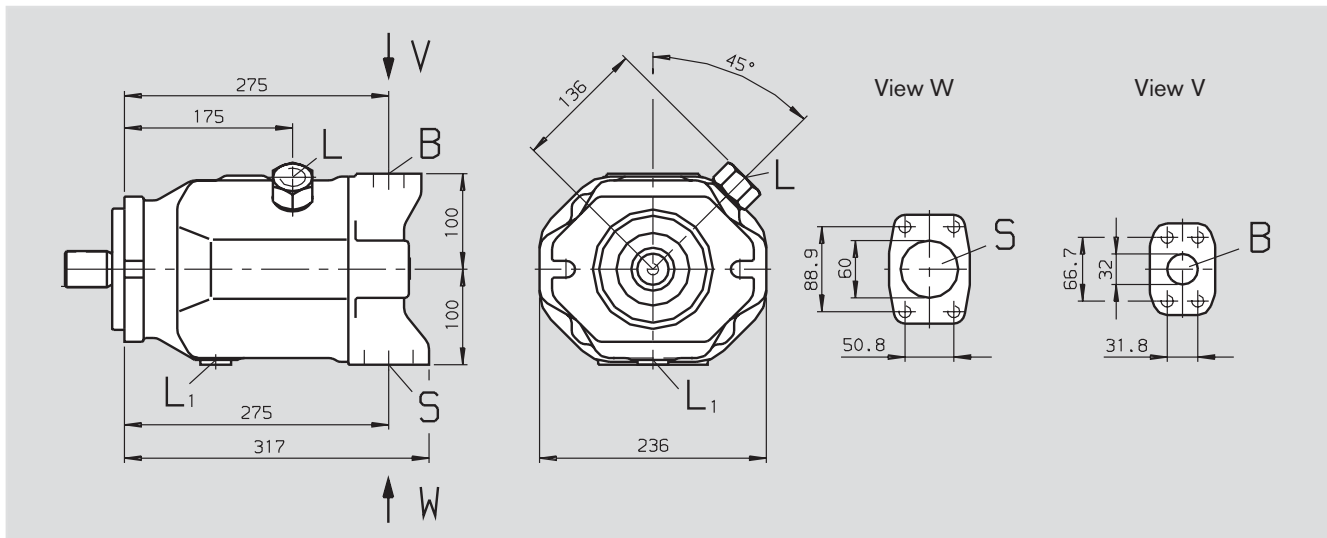

## Shaft ends (acc.to SAE J744 OCT83)

**S** Splined shaft 1 1/2in-17T 12/24DP <sup>1)</sup>  
(similar to SAE J744 - 38-4 (C-C))

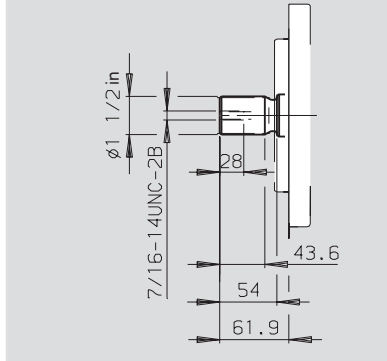

**U** Splined shaft 1 1/4in-14T 12/24DP <sup>1)</sup>  
(similar to SAE J744 - 32-4 (C))

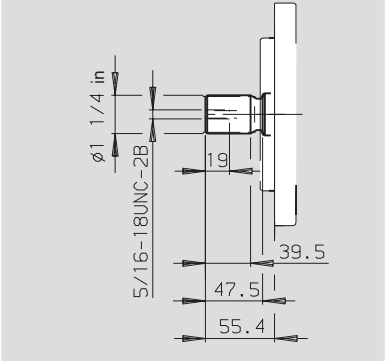

**W** Splined shaft 1 1/4in-14T 12/24DP <sup>1)</sup>  
(similar to SAE J744 - 32-4 (C))

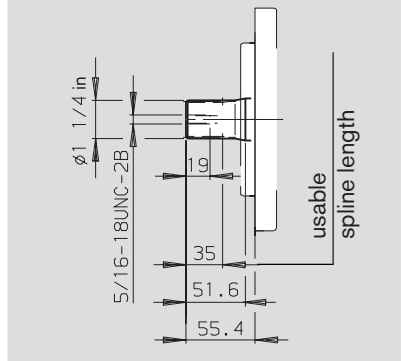

## Ports

B	Pressure port (Standard pressure range)	SAE J518	1 1/4 in	205 Nm
	Fixing thread	DIN 13	M14x2; 19 deep	
S	Inlet port (Standard pressure range)	SAE J518	2 1/2 in	130 Nm
	Fixing thread	DIN 13	M12x1,75; 17deep	
L	Drain port	DIN 3852-1	M27x2	330 Nm
L <sub>1</sub>	Drain port (closed)	ISO 11926	1 1/16-12 UN-2B	360 Nm

## Tightening torques, max. <sup>2)</sup>

<sup>1)</sup> ANSI B92.1a-1976, 30° pressure angle, flat base, flank centering, fit class 5

<sup>2)</sup> See safety information

# Unit dimensions size 100

Before finalising your design please request a certified installation drawing.

## Version 61 N00

Ports at rear, no through drive (without control valves)

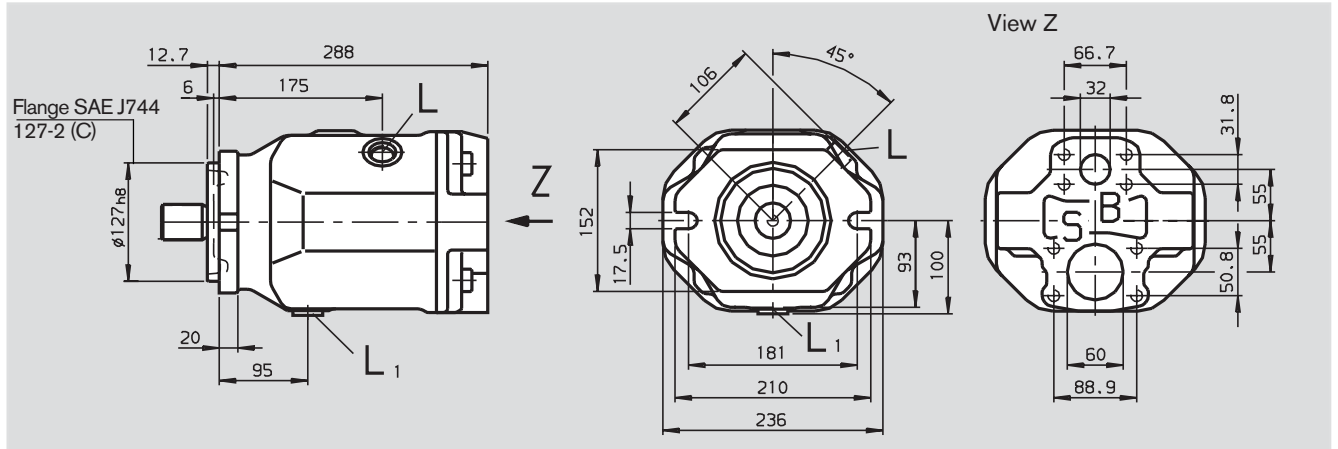

## Version 62 N00

Ports on side, no through drive

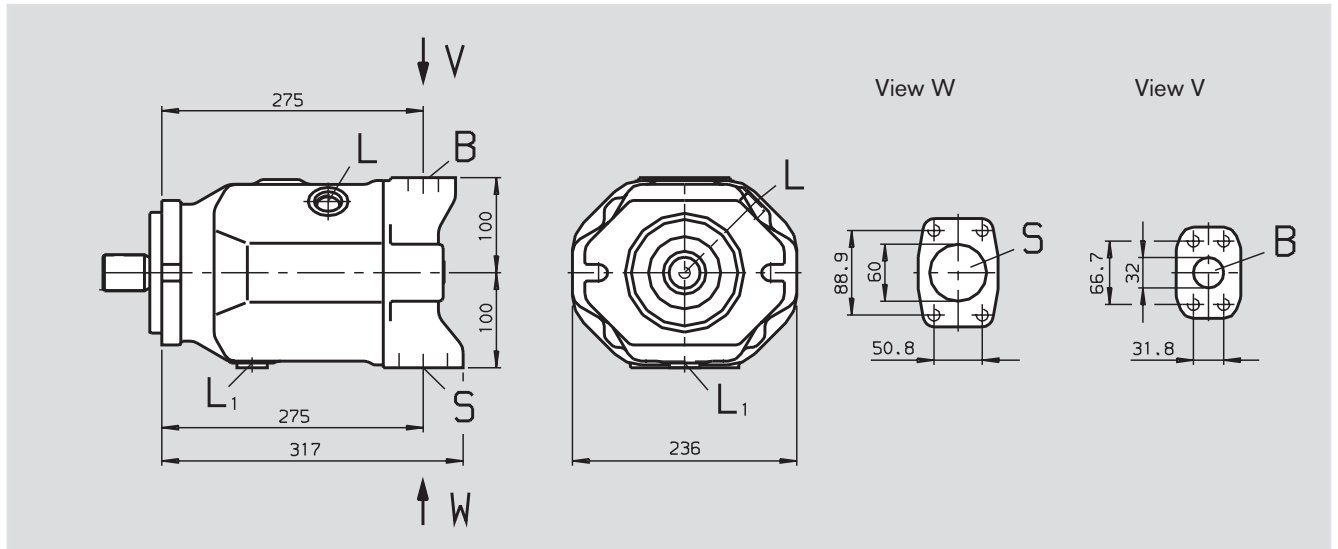

### Ports

B	Pressure port (Standard pressure range)	SAE J518	1 1/4 in
	Fixing thread		1/2-13UNC-2B; 19 deep
S	Inlet port (Standard pressure range)	SAE J518	2 1/2 in
	Fixing thread		1/2-13UNC-2B; 27 deep
L, L <sub>1</sub>	Drain ports (L <sub>1</sub> closed)	ISO 11926	1 1/16-12 UN-2B

<sup>1)</sup> See safety information

### Tightening torques, max. <sup>1)</sup>

90 Nm
90 Nm
360 Nm

# Unit dimensions size 140

Before finalising your design please request a certified installation drawing.

## Version 11 N00

Ports at rear, no through drive (without control valves)

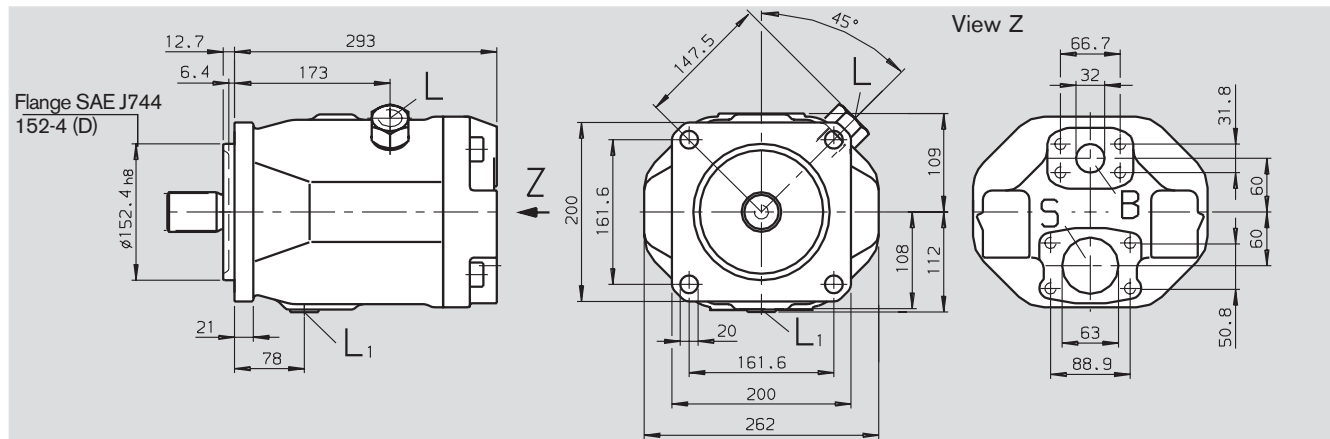

## Version 12 N00

Ports on side, no through drive

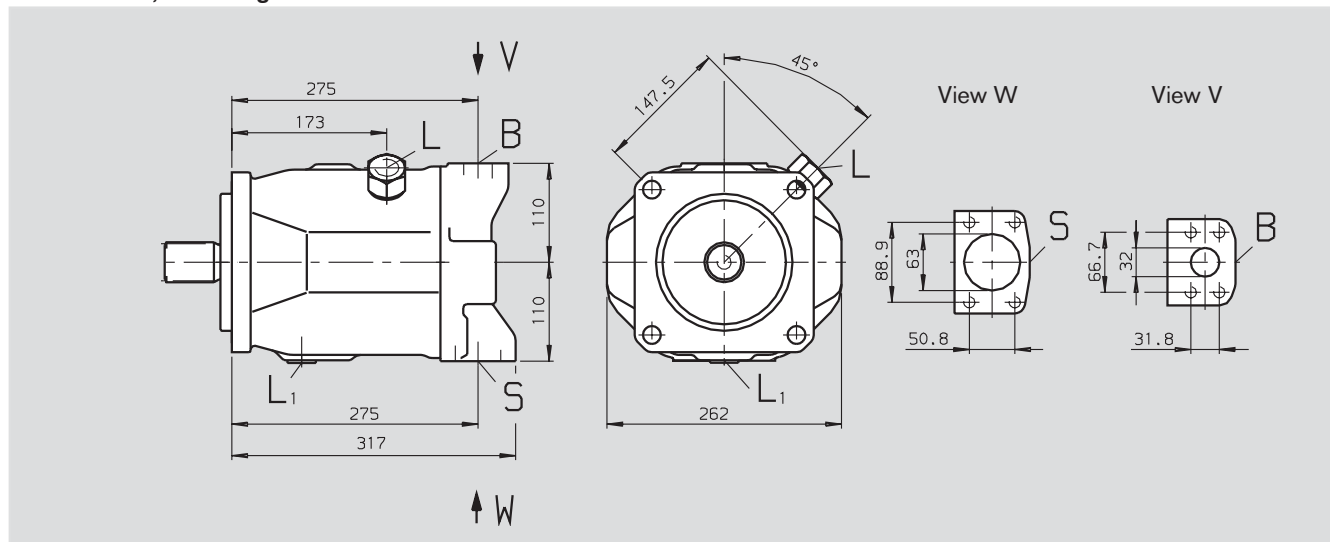

## Shaft ends (acc. to SAE J744 OCT83)

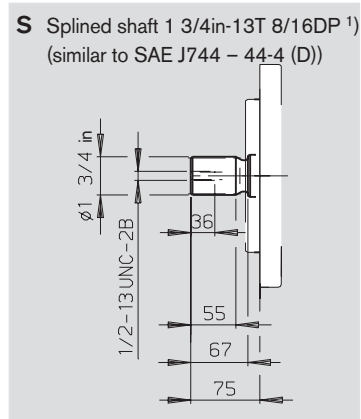

## Ports

Port	Description	SAE	Size	Tightening torques, max. <sup>2)</sup>
B	Pressure port (Standard pressure range)	SAE J518	1 1/4 in	205 Nm
	Fixing thread	DIN 13	M14x2; 19 deep	
S	Inlet port (Standard pressure range)	SAE J518	2 1/2 in	130 Nm
	Fixing thread	DIN 13	M12x1,75; 17 deep	
L	Drain port	DIN 3852-1	M27x2	330 Nm
$L_1$	Drain port(closed)	ISO 11926	1 1/16-12 UN-2B	360 Nm

<sup>1)</sup> ANSI B92.1a-1976, 30° pressure angle, flat base, flank centering, fit class 5

<sup>2)</sup> See safety information



# Unit dimensions size 140

Before finalising your design please request a certified installation drawing.

## Version 61 N00

Ports at rear, no through drive (without control valves)

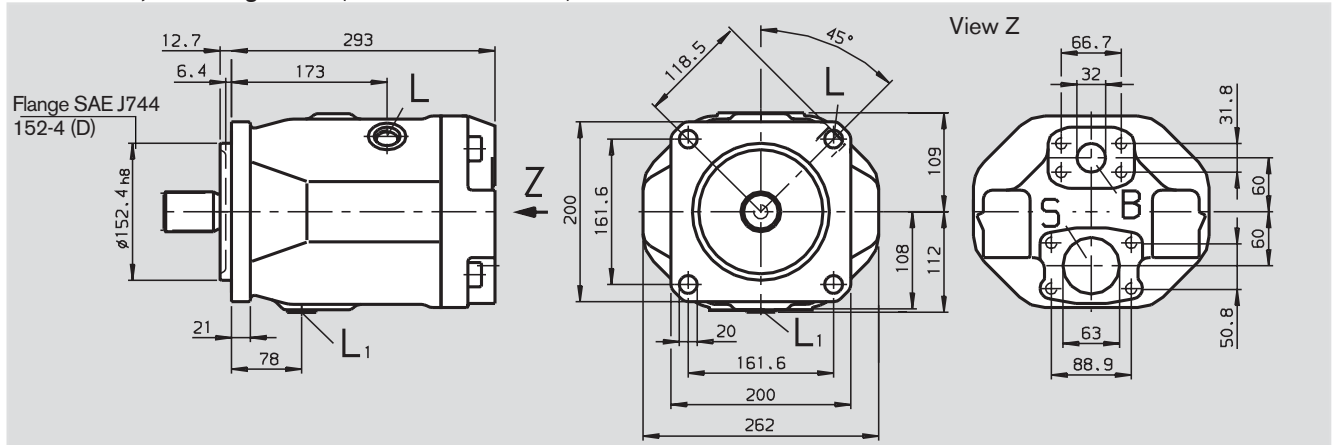

## Version 62 N00

Ports on side, no through drive

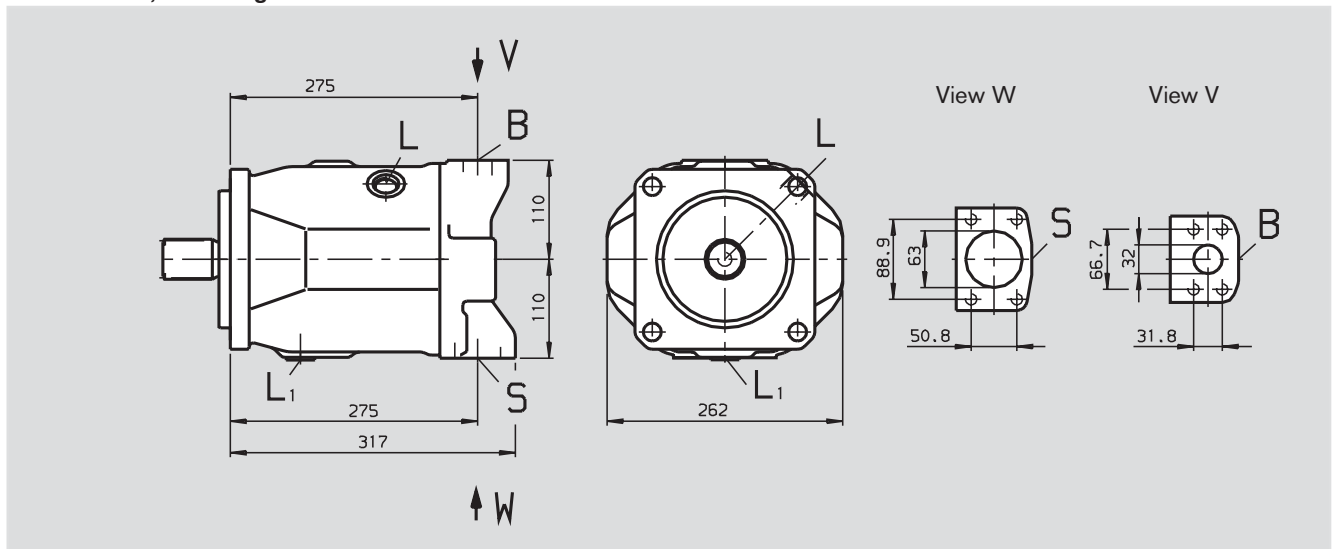

### Ports

B	Pressure port (Standard pressure range)	SAE J518	1 1/4 in
	Fixing thread		1/2-13UNC-2B; 24 deep
S	Inlet port (Standard pressure range)	SAE J518	2 1/2 in
	Fixing thread		1/2-13UNC-2B; 24 deep
L, L <sub>1</sub>	Drain ports (L <sub>1</sub> closed)	ISO 11926	1 1/16-12 UN-2B

<sup>1)</sup> See safety information

### Tightening torques, max. <sup>1)</sup>

90 Nm
90 Nm
360 Nm

## Through drives

Axial piston units A10V(S)O can be supplied with a through drive as shown in the ordering code on page 3. The type of through drive is determined by codes (K01–K24). If the combination pump is not mounted in the factory, the simple type code is sufficient.

Included in this case are: Shaft coupler, seals, and if necessary an adapter flange.

### Maximum permissible input and through drive torques

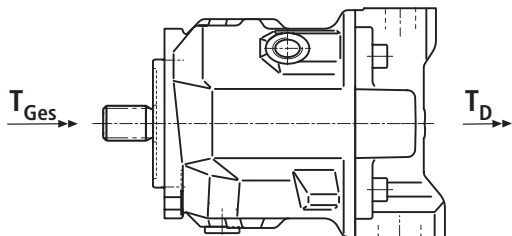

The drive torques for pump 1 and pump 2 can be split up as required. However the max. permissible input torque  $T_{tot}$  as well as the max. permissible through drive torque  $T_{thr}$  may not be exceeded.

Size			18	28	45	71	100	140
Max. perm. input torque $T_{tot}$								
With shaft S	$T_{tot}$	N m	100	198	319	626	1104	1620
With shaft R	$T_{tot}$	N m	143	225	400	644	-	-
Max. perm. through drive torque $T_{thr}$								
With shaft S	$T_{thr}$	N m	80	160	319	492	778	1266
With shaft R	$T_{thr}$	N m	80	176	365	548	-	-

$T_{tot}$  = Max. permissible input torque pump 1

$T_{thr}$  = Max. permissible through drive torque at 2<sup>nd</sup> shaft end of pump 1.

### Permissible moment of inertia

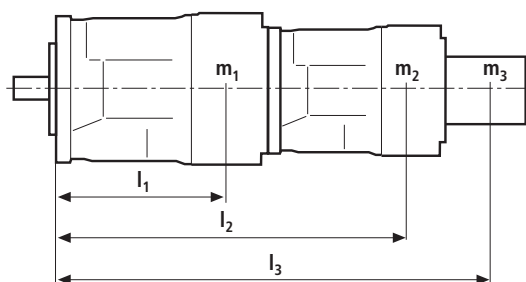

$m_1, m_2, m_3$  Weight of pump in kg

$l_1, l_2, l_3$  Distance to center of gravity in mm

$$T_m = (m_1 \cdot l_1 + m_2 \cdot l_2 + m_3 \cdot l_3) \cdot \frac{1}{102} \text{ in Nm}$$

Size			18	28	45	71	100	140
Perm. moment of inertia	$M_{mper}$	N m	500	880	1370	2160	3000	4500
at dyn. acceleration 10g 98,1 m/sec <sup>2</sup>	$M_{mper}$	N m	50	88	137	216	300	450
Weight	m	kg	12	15	21	33	45	60
Distance to center of gravity	$l_1$	m m	90	110	130	150	160	160

# Overview of through drive mounting options

Before finalising your design please request a certified installation drawing.

Through drive - A10V(S)O		Code	Mounting option - 2. pump		Gear pump	Through dr. available on size
Flange (ISO 3019-1)	Coupler for shaft (ISO 3019-1)		A10V(S)O../31... Size (shaft)	A10V(S)O../52... Size (shaft)		
82-2 (A)	16-4 (5/8in)	<b>K01</b>	18 (U)		Size F	18 – 140
	19-4 (3/4in)	<b>K52</b>	18 (S and R)	10 (S)		18 – 140
101-2 (B)	22-4 (7/8in)	<b>K02</b>			Size N and G	28 – 140
		<b>K68</b>	28 (S and R) 45 (U and W) <sup>1)</sup>	28 (S and R) 45 (U and W) <sup>1)</sup>		28 – 140
127-2(C)	25-4 (1in)	<b>K04</b>	45 (S and R)	45 (S and R) 60 (U and W) <sup>2)</sup>		45 – 100
	32-4 (1 1/4in)	<b>K07</b>	71 (S and R) 100 (U) <sup>3)</sup>	85 (U and W) <sup>3)</sup>		71 – 140
152-4 (4-hole)	38-4 (1 1/2in)	<b>K24</b>	100 (S)	85 (S)		100 – 140
	44-4 (1 3/4in)	<b>K17</b>	140 (S)			140

<sup>1)</sup> Not with K68-through drive on main pump size 28

<sup>2)</sup> Not with K04-through drive on main pump size 45

<sup>3)</sup> Not with K07-through drive on main pump size 71

## Unit dimensions combination pumps A10V(S)O + A10V(S)O

A10V(S)O (1. Pump)	A10V(S)O (2.Pumpe)																							
	A10VSO 18				A10VO 28				A10VO 45				A10VO 71				A10VO 100				A10VO 140			
	A <sub>1</sub>	A <sub>2</sub>	A <sub>3</sub>	A <sub>4</sub>	A <sub>1</sub>	A <sub>2</sub>	A <sub>3</sub>	A <sub>4</sub>	A <sub>1</sub>	A <sub>2</sub>	A <sub>3</sub>	A <sub>4</sub>	A <sub>1</sub>	A <sub>2</sub>	A <sub>3</sub>	A <sub>4</sub>	A <sub>1</sub>	A <sub>2</sub>	A <sub>3</sub>	A <sub>4</sub>	A <sub>1</sub>	A <sub>2</sub>	A <sub>3</sub>	A <sub>4</sub>
<b>A10VSO 18</b>	145	182	327	377	165	204	349	399	184	229	374	424	217	267	412	462	275	338	483	533	275	350	495	545
<b>A10VO 28</b>	-	-	-	-	165	204	369	398	184	229	394	423	217	267	432	461	275	338	503	532	275	350	515	544
<b>A10VO 45</b>	-	-	-	-	-	-	-	-	184	229	413	448	217	267	451	486	275	338	522	557	275	350	534	569
<b>A10VO 71</b>	-	-	-	-	-	-	-	-	-	-	-	-	217	267	484	524	275	338	555	595	275	350	567	607
<b>A10VO 100</b>	-	-	-	-	-	-	-	-	-	-	-	-	-	-	-	-	275	338	631	664	275	350	625	679
<b>A10VO 140</b>	-	-	-	-	-	-	-	-	-	-	-	-	-	-	-	-	-	-	-	-	275	350	625	688

- If a **second Rexroth pump must be factory mounted** the two individual model codes must be combined with a „+“. Model code pump 1+ model code pump 2.

**Ordering example :**

A10VO 100DR/31R-PSC12K07 + A10VO 71DR/31R-PSC12N00

- If a **gear pump or a radial piston pump is to be factory mounted** as a second pump please consult the factory.

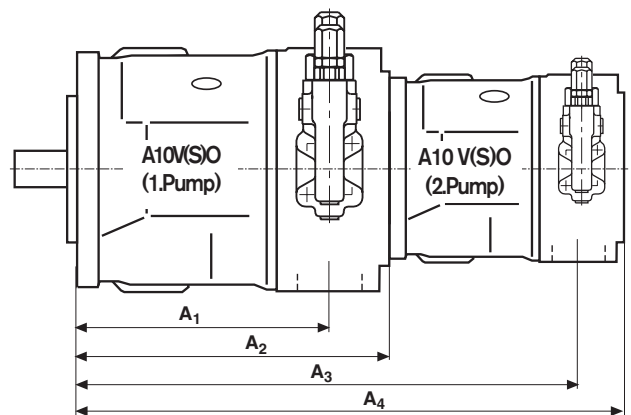

# Dimensions of through drives

Before finalising your design please request a certified installation drawing.

## K01

for mounting a pump with **flange 82-2** (ISO 3019-1) and **Shaft 16-4** (SAE J744 OCT83), eg. A10VSO18...with U-Shaft

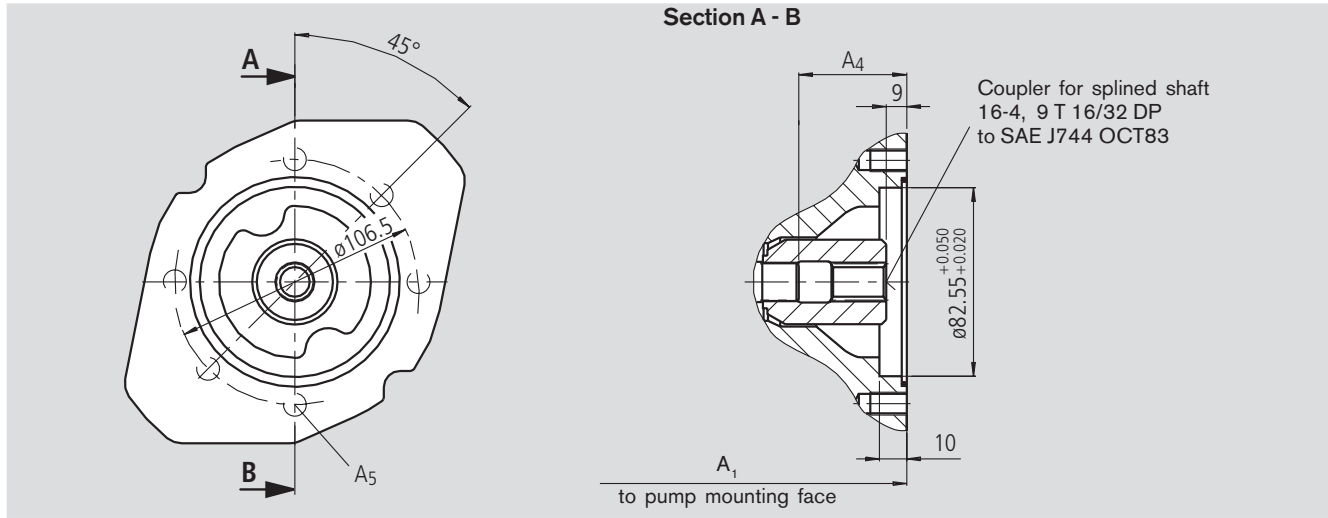

Size main pump	A <sub>1</sub>	A <sub>4</sub>	A <sub>5</sub>
18	182	42	M10; 14 deep
28	204	47	M10; 14,5 deep
45	229	53	M10; 14,5 deep
71	267	61	M10; 17 deep
100	338	65	M10; 17 deep
140	350	77	M10; 17 deep

## K52

for mounting a pump with **flange 82-2** (ISO 3019-1) and **shaft 19-4** (SAE J744 OCT83), eg. A10VSO18...with S- or R-shaft

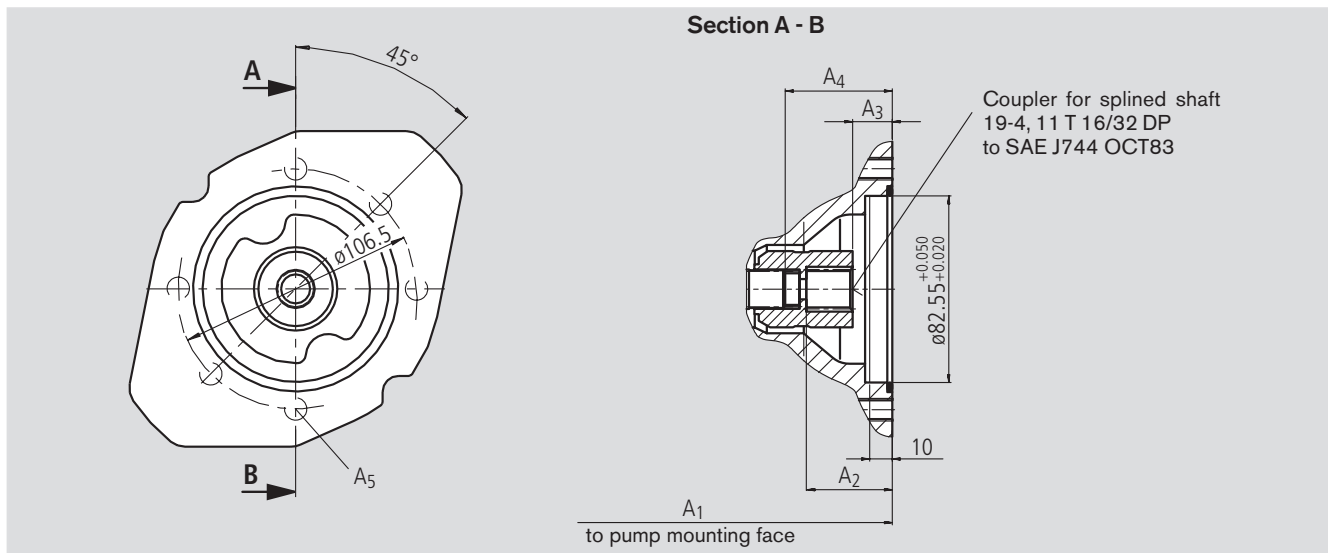

Size main pump	A <sub>1</sub>	A <sub>2</sub>	A <sub>3</sub>	A <sub>4</sub>	A <sub>5</sub>
18	182	40	17,5	43	M10; 16 deep
28	204	39	17,5	47	M10; 16 deep
45	229	40,5	17,5	53	M10; 16 deep
71	267	40	17,5	61	M10; 20 deep
100	338	40	17,5	65	M10; 20 deep
140	350	41	17,5	77	M10; 20 deep

# Dimension of through drives

Before finalising your design please request a certified installation drawing.

## K02

for mounting a pump with **flange 101-2** (ISO 3019-1SAE J744 OCT83) and **shaft 22-4** (SAE J744 OCT83)

Radial O-Ring seal at pilot diameter

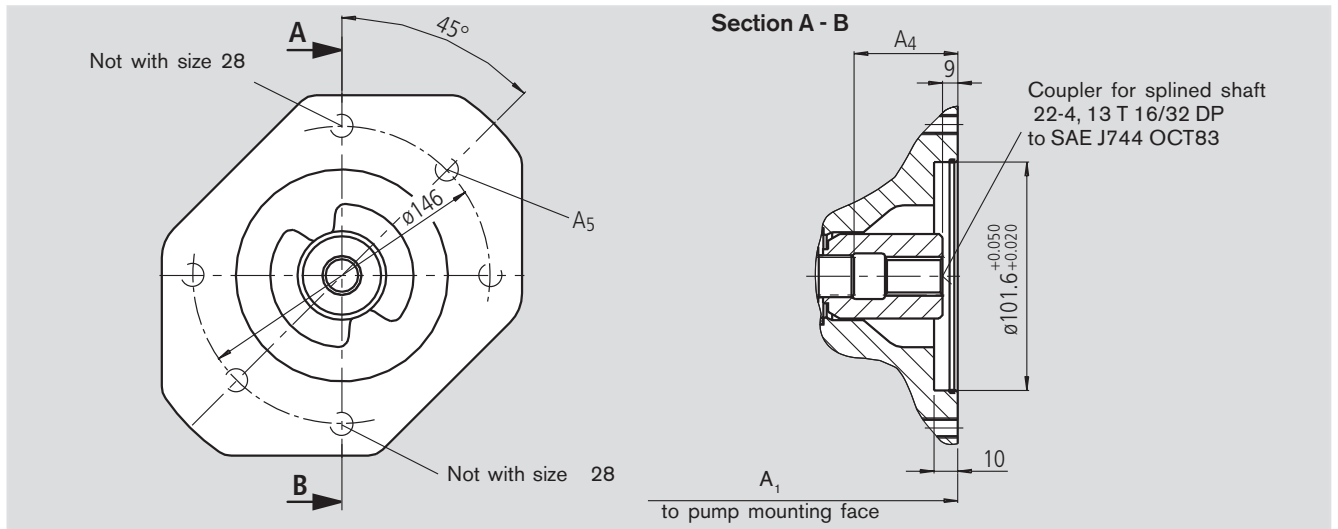

Size main pump	A <sub>1</sub>	A <sub>4</sub>	A <sub>5</sub>
28	204	47	M12; 15 deep
45	229	53	M12; 18 deep
71	267	61	M12; 20 deep
100	338	65	M12; 20 deep
140	350	77	M12; 20 deep

## K68

for mounting a pump with **flange 101-2** (ISO 3019-1) and **shaft 22-4** (SAE J744 OCT83), z.B. A10VO28...with S- or R-shaft

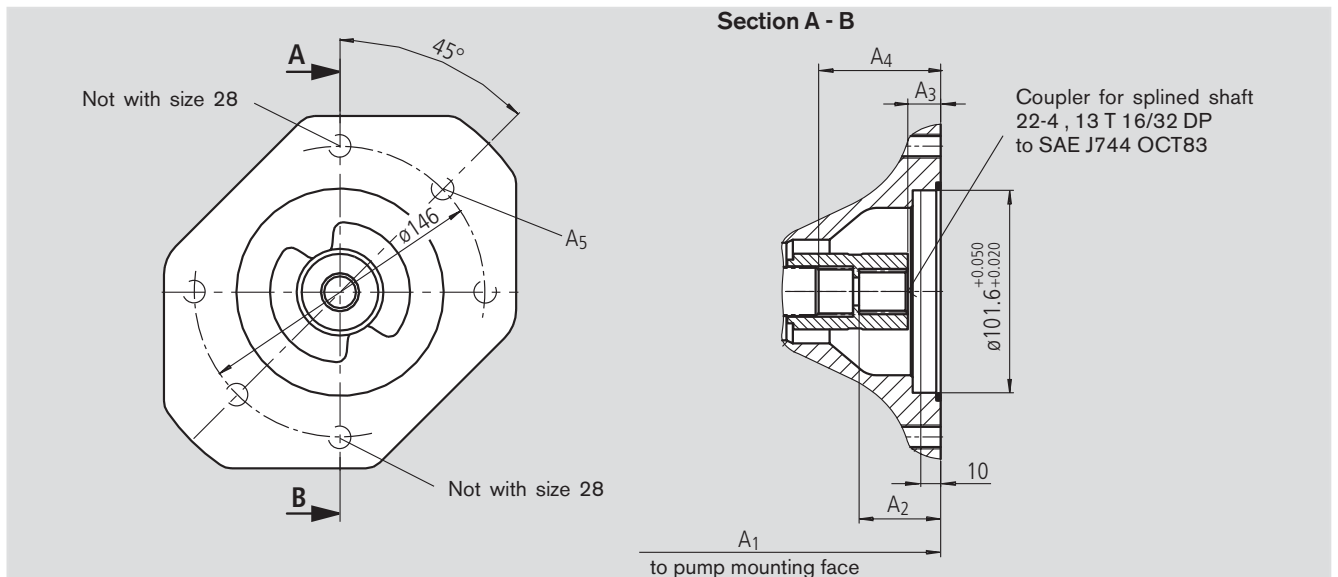

Size main pump	A <sub>1</sub>	A <sub>2</sub>	A <sub>3</sub>	A <sub>4</sub>	A <sub>5</sub>
28	204	43	16,5	47	M12; 15 deep
45	229	42	16,5	53	M12; 18 deep
71	267	43	16,5	61	M12; 20 deep
100	338	41	16,5	65	M12; 20 deep
140	350	44	16,5	77	M12; 20 deep

# Dimensions through drives

Before finalising your design please request a certified installation drawing.

## K04

for mounting a pump with **flange 101-2** (ISO 3019-1) and shaft **25-4** (SAE J744 OCT83) eg. A10VO 45... with S- or R-shaft

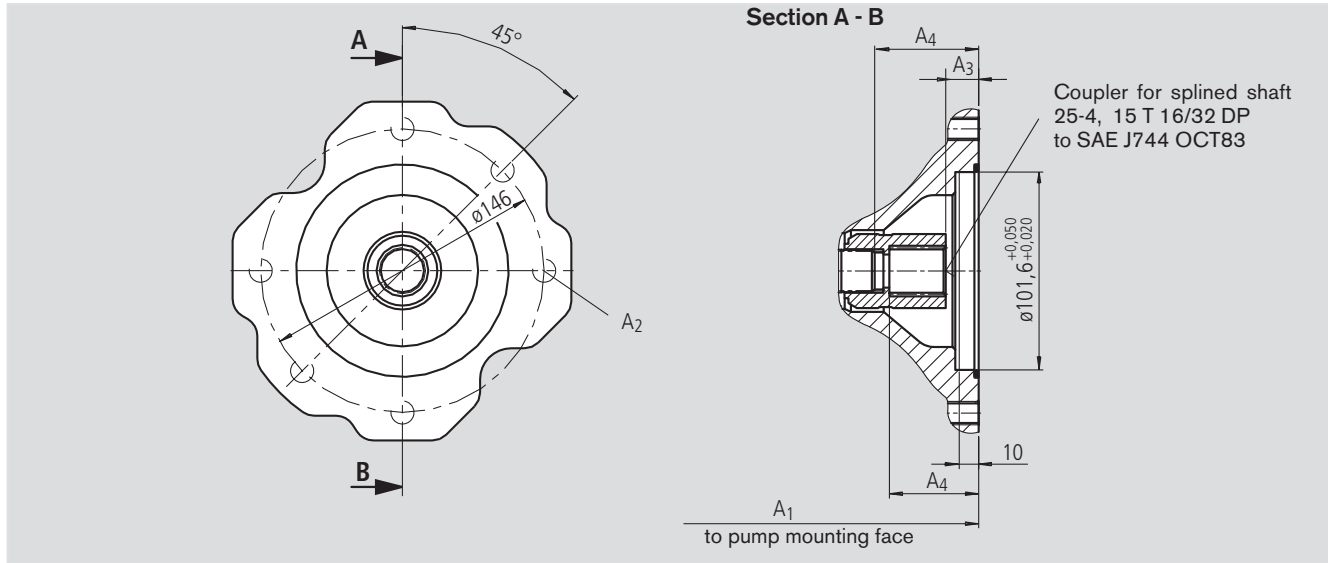

Size main pump	A <sub>1</sub>	A <sub>2</sub>	A <sub>3</sub>	A <sub>4</sub>	A <sub>5</sub>
45	229	47,5	16,9	53	M12; 18 deep
71	267	47,5	16,9	61	M12; 20 deep
100	338	47,5	16,9	65	M12; 20 deep

## K07

for mounting a pump with **flange 127-2** (ISO 3019-1) and **shaft 32-4** (SAE J744 OCT83) eg. A10VO 71... with S- or R-shaft

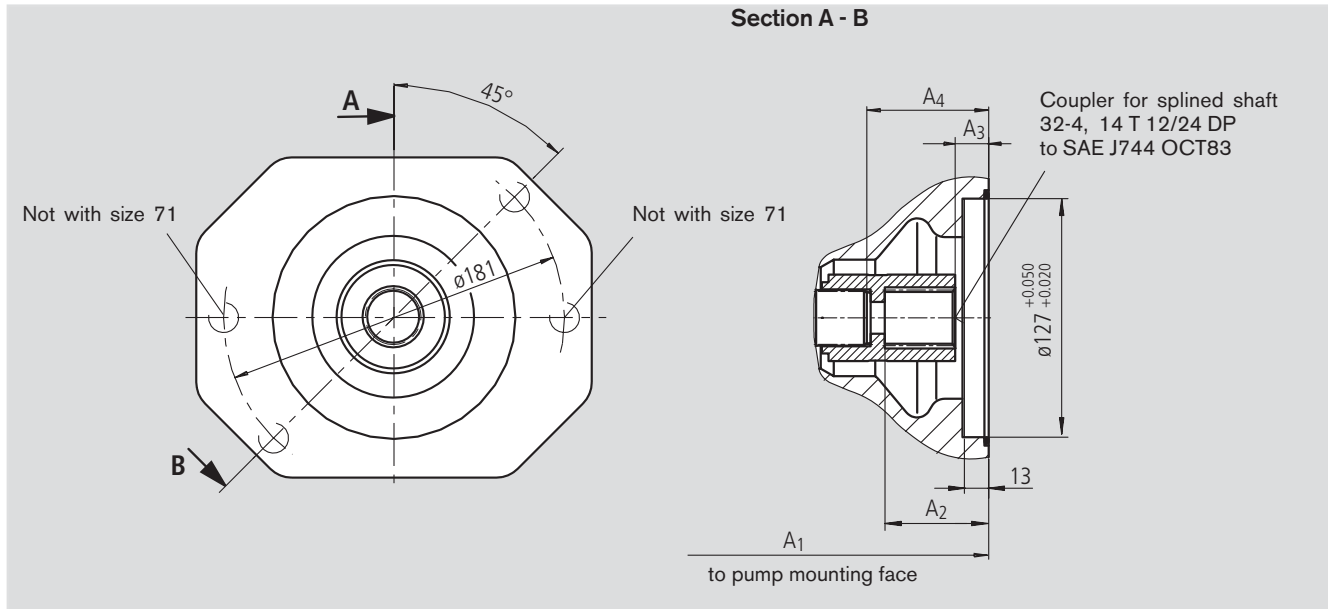

Size main pump	A <sub>1</sub>	A <sub>2</sub>	A <sub>3</sub>	A <sub>4</sub>	A <sub>5</sub>
71	267	55,5	17,9	61	M16; 18 deep
100	338	57	17,9	65	M16; 25 deep
140	350	60	17,9	77	M16; 32 deep

# Dimensions through drives

Before finalising your design please request a certified installation drawing.

## K24

for mounting a pump with **flange 127-2** (ISO 3019-1) and **shaft 38-4** (SAE J744 OCT83) eg. A10VO 100... with S-shaft

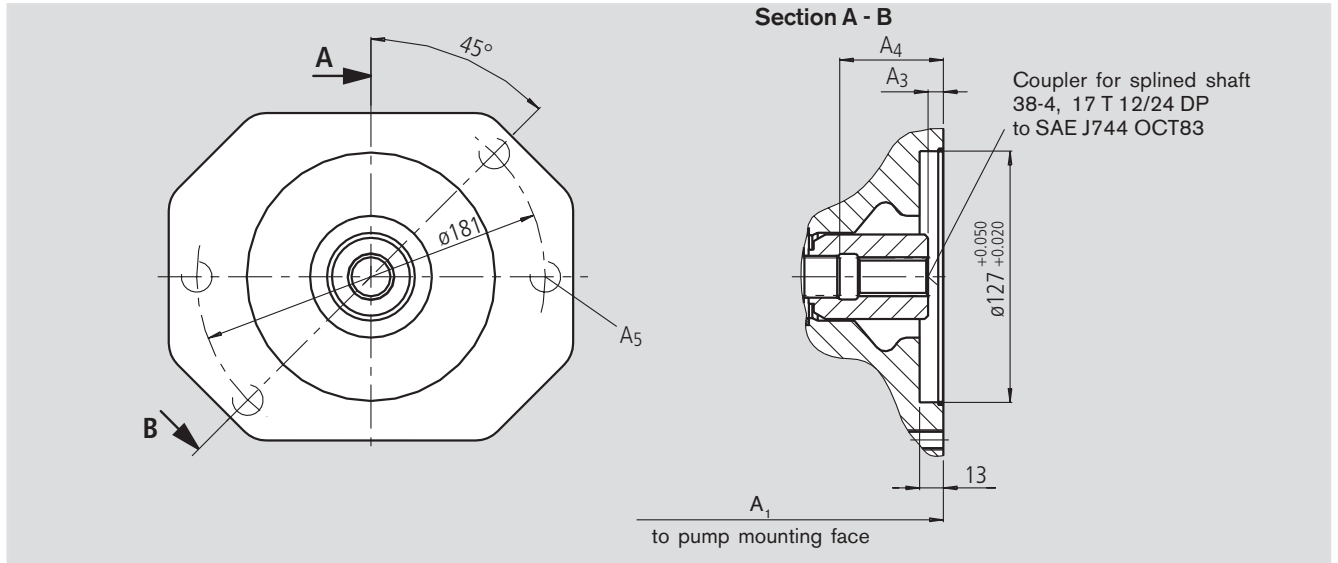

Size main pump	A <sub>1</sub>	A <sub>3</sub>	A <sub>4</sub>	A <sub>5</sub>
100	338	8	65	M16; 20 deep
140	350	9	77,3	M16; 32 deep

## K17

for mounting a pump with **flange 152-4** (ISO 3019-1) and **shaft 44-4** (SAE J744 OCT83) z.B. A10VO 140... with S-shaft

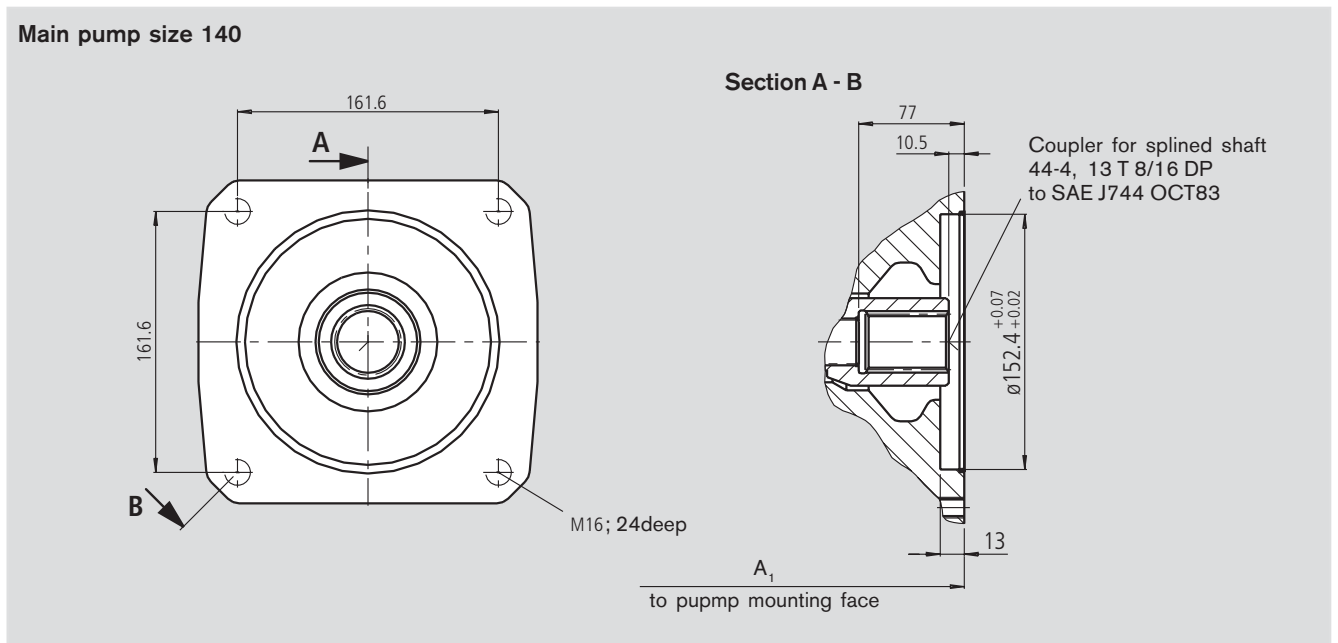

# Installation notes

Optional installation position. The pump housing must be filled with fluid during commissioning and operation.

In order to attain the lowest noise level, all connections (suction, pressure, pilot, case drain) must be linked by flexible members to tank.

Avoid placing a check valve in the case drain line. In some cases it may be permissible however. Please consult us.

At the high-altitude leakage oil port according to the port size the largest pipe out of the standard row has to be installed.

## 1. Vertical installation (Shaft end upwards)

The following installation conditions must be taken into account:

### 1.1 Arrangement inside the reservoir

Before installation fill pump housing, keeping it in a horizontal position..

a) If the min. fluid level is equal to or above the pump mounting surface:

Close port „L“, „L<sub>1</sub>“ and „S“ open; L<sub>1</sub> piped and also S with suction pipe (see Fig. 1).

b) If the min. fluid level is below the pump mounting surface: pipe port „L“ and „S“ acc. to fig. 2. Conditions acc. to item 1.2.1, close port „L“

**Note:** In order to avoid damages at the pump, all attached parts (e.g. protective caps, covers, etc.) must be removed before installation.

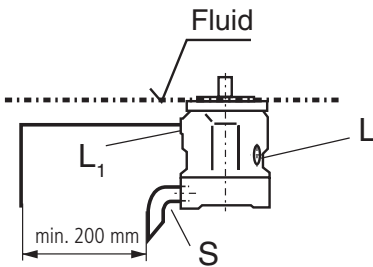

Fig. 1

### 1.2 Arrangement outside the reservoir

Before installation fill pump housing, keeping it in a horizontal position. For mounting above the tank see fig. 2.

Limiting condition:

1.2.1 Min. pump inlet pressure  $p_{abs\ min} = 0,8$  bar under static and dynamic loading.

Note: Avoid mounting above tank wherever possible in order to attain a low noise level.

The permissible suction height  $h$  is a result of the overall pressure loss, but may not be greater than  $h_{max} = 800$  mm (Immersion depth  $h_{t\ min} = 200$  mm).

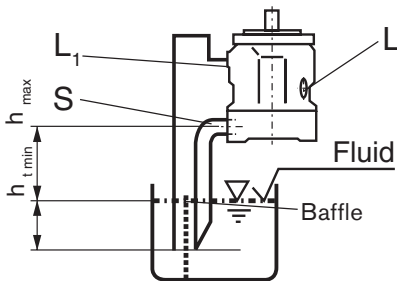

Fig. 2

Total pressure losst  $\Delta p_{Ges} = \Delta p_1 + \Delta p_2 + \Delta p_3 \leq (1 - p_{abs\ min}) = 0,2$  bar

$\Delta p_1$ : Pressure loss in pipe due to accelerating column of fluid

$$\Delta p_1 = \frac{\rho \cdot l \cdot dv}{dt} \cdot 10^{-5} \text{ (bar)}$$

$\rho$  = density (kg/m<sup>3</sup>)  
 $l$  = pipe length (m)  
 $dv/dt$  = change in fluid velocity suction pipe (m/s<sup>2</sup>)

$\Delta p_2$ : Pressure loss due to static head

$$\Delta p_2 = h \cdot \rho \cdot g \cdot 10^{-5} \text{ (bar)}$$

$h$  = height (m)  
 $\rho$  = density (kg/m<sup>3</sup>)  
 $g$  = acc. due to gravity. = 9,81 m/s<sup>2</sup>

$\Delta p_3$ : Line losses (Elbows etc.)

## 2. Horizontal installation

The pump must be installed in such a manner, that either „L“ or „L<sub>1</sub>“ is at the top.

### 2.1 Arrangement inside the reservoir

a) If the min. fluid level is above the top of the pump:

Close „L<sub>1</sub>“, „L“ and „S“ open, mount suction pipe to port S, and pipe „L“ at least 200 mm away from suction pipe. (see fig. 3)

b) If the min. fluid level is equal to or below the top of the pump:

Pipe port „L“ and „S“ acc. to fig. 4, port „L<sub>1</sub>“ closed. Conditions correspond with item 1.2.1

**Note:** In order to avoid damages at the pump, all attached parts (e.g. protective caps) must be removed.

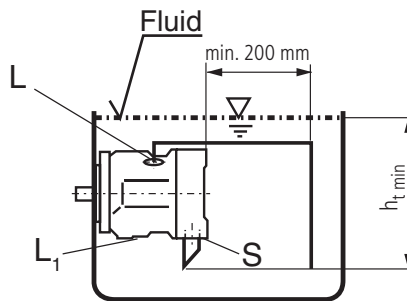

Fig. 3

### 2.2 Arrangement outside the reservoir

Fill pump housing before commissioning.

Pipe port „S“ and the higher of the two case drain ports „L“ or „L<sub>1</sub>“.

a) For mounting above tank see fig. 4.

Conditions correspond with item 1.2.1

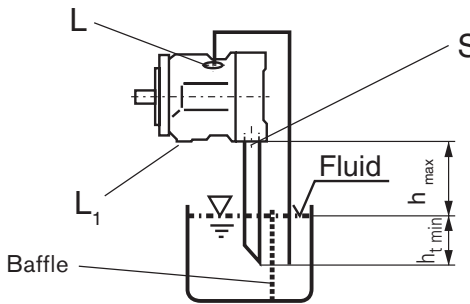

Fig. 4

b) Position below tank

Pipe port „L<sub>1</sub>“ and „S“ acc. to fig. 5, port „L“ closed.

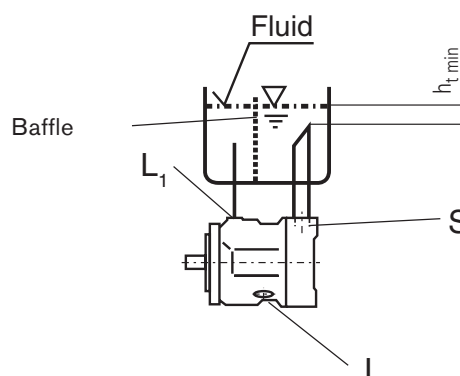

Fig. 5



## Safety information

- Pump A10V(S)O was designed for operation in open loop circuits.
- Systems design, installation and commissioning requires trained technicians or tradesmen.
- All hydraulic ports can only be used for the fastening of hydraulic service lines .
- Tightening torques: please comply with the manufacturer's information regarding the max. permissible tightening torques for the used fittings.  
For fastening screws to DIN 13 we recommend to check the permissible tightening torques in each individual case acc. to VDI 2230 dated 2003.
- During and shortly after operation of a pump the housing and especially a solenoid can be extremely hot, avoid being burned!





Bosch Rexroth AG  
Mobile Hydraulics  
Product Segment Axial Piston Units  
Plant Horb  
An den Kelterwiesen 14  
72160 Horb, Germany  
Telefon +49 (0) 74 51 92-0  
Telefax +49 (0) 74 51 82 21  
info.brm-ak@boschrexroth.de  
[www.boschrexroth.com/axial-piston-pumps](http://www.boschrexroth.com/axial-piston-pumps)

© 2003 by Bosch Rexroth AG, Mobile Hydraulics, 89275 Elchingen  
All rights reserved. No part of this document may be reproduced or stored, processed, duplicated or circulated using electronic systems, in any form or by any means, without the prior written authorization of Bosch Rexroth AG. In the event of contravention of the above provisions, the contravening party is obliged to pay compensation.  
The data specified above only serve to describe the product. No statements concerning a certain condition or suitability for a certain application can be derived from our information. The given information does not release the user from the obligation of own judgement and verification. It must be remembered that our products are subject to a natural process of wear and aging.